

# TUNING FORK

Quarterly audio service guide

No.2

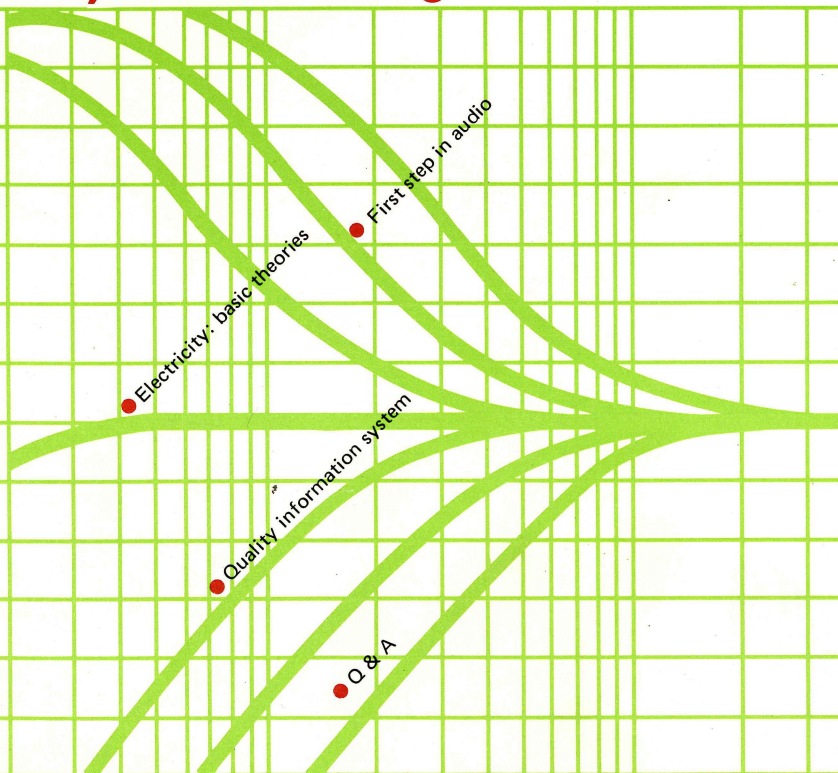

# CONTENTS

---

<b>Parts Information (2)</b>	
Capacitors . . . . .	2
<b>New Products</b>	
PL-570 . . . . .	17
<b>One-point Servicing Techniques (2)</b>	
Tracking Adjustment. . . . .	41
<b>Measuring Instruments (2)</b>	
Multimeters—2 . . . . .	47
<b>Electricity: Basic Theories</b>	
Ohm's Law—2 . . . . .	56
<b>First Step in Audio (1)</b>	
Specifications—1 . . . . .	60
<b>Quality Information System . . . . .</b>	<b>67</b>
<b>Audio Memo</b>	
Pink Noise and White Noise. . . . .	72
<b>Q &amp; A . . . . .</b>	<b>73</b>
<b>In the Next Issue. . . . .</b>	<b>75</b>
<b>Editor's Note. . . . .</b>	<b>75</b>

---

# Parts Information (2)

## Capacitors

Like resistors, capacitors have a wide application in electronic circuit design. Selection is made according to where they are to be located in the circuit and depends on many factors. Such things as working voltage, capacitance tolerance, high-frequency characteristics, loss of thermal characteristics, high/low temperature characteristics; their form and capacitance must all be taken into consideration.

It is important to note that one capacitor cannot always replace another of the same capacitance and/or size, therefore, a knowledge of capacitor characteristics is essential when replacing or reordering them.

### 1. Principle of the Capacitor (Condenser)

Basically, a capacitor consists of two parallel metal plates (electrodes), separated by an expanse of air. When a DC voltage is supplied across the electrodes,

an electric charge proportional to the DC voltage supplied is stored between them. The polarity of the charge depends on that of the voltage supplied (positive to electrode A or B). The larger the area of the electrodes, and the closer the distance between them, the larger the electric charge (capacitance) becomes. And if a piece of insulation material is placed between the electrodes, the capacitance becomes even higher.

Now, supposing the capacitance, or more precisely, the electrostatic capacitance of a capacitor without an insulation insert (with a vacuum) is  $C$ , then the capacitance with an insulation insert would be  $\epsilon_s$  times  $C$  ( $\epsilon_s$  being larger than 1). The multiplier  $\epsilon_s$  is known as the specific inductive capacity.

The value of  $\epsilon_s$  differs with the kind of insulation material used. Material which gives a particularly high  $\epsilon_s$  value is called dielectric.

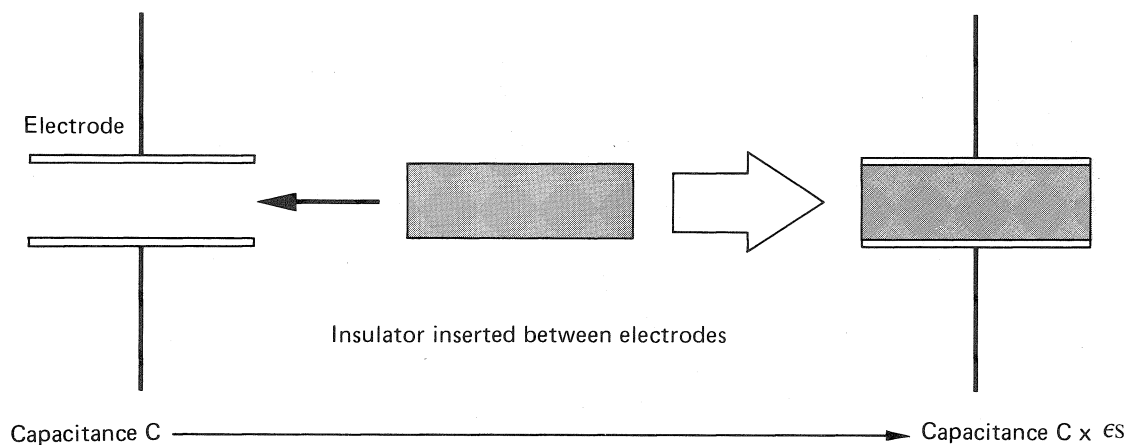

Fig. 1 Capacitance increased by dielectric

Although there are many kinds of capacitors available, most of them are of the dielectric type.

The basic unit of capacitance is the Farad (unit F). One Farad is defined as a capacitance which can store a charge of 1 Coulomb (C) when a voltage of 1 volt (V) is supplied across the terminals. However, since the Farad is too large for practical application, smaller units of capacitance like micro-Farad ( $\mu\text{F}$ ) and pico-Farad (pF) are used. Their relationship to the Farad are as follows:

$$1\mu\text{F} = 10^{-6} \text{ F}$$

$$1\text{pF} = 10^{-12} \text{ F}$$

Therefore  $0.001\mu\text{F}$  equals 1,000pF. Capacitance values of less than  $0.001\mu\text{F}$  are usually expressed in pico-Farads.

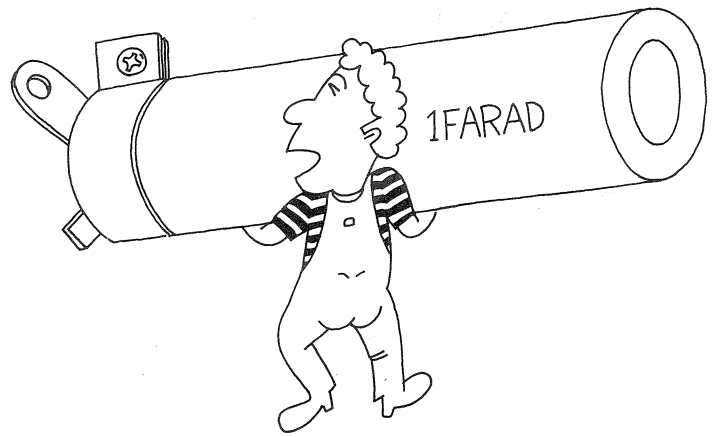

Fig. 2 Farad too large as a unit of capacitance

### Classification of Capacitors

Listed below are the fifteen types of capacitors that are used in Pioneer audio products.

CE	Aluminum Electrolytic Capacitors
CSY	Solid Aluminum Electrolytic Capacitors
CSS	Solid Aluminum Electrolytic Capacitors for Coupling
CSZ	Solid Tantalum Electrolytic Capacitors
CK	Ceramic Capacitors with High Dielectric Constant
CC	Ceramic Capacitors for Thermal Compensation
CM	Mica Capacitors
CQM	Mylar Capacitors
CQS	Polystyrene Film Capacitors
CQC	Polycarbonate Film Capacitors
CP	Oil-filled Paper Capacitors
CG	Ceramic Capacitors
CQE	Metalized Mylar Film Capacitors
CQP	Polypropylene Film Capacitors
CH	Metalized Paper Capacitors

The codes in the lefthand column are used in the Parts List.

### Parts Numbers of Capacitors

The parts numbers of Pioneer capacitors are broken down into seven codes.

For example:

CE	A	NL	101	M	50	NP	1. Type of capacitor
1	2	3	4	5	6	7	2. Form
							3. Characteristics
							4. Nominal capacitance
							5. Tolerance
							6. Maximum working voltage
							7. Miscellaneous

The miscellaneous code 7 (NP) is used exclusively to indicate a non-polar electrolytic capacitor.

2. Type of Capacitors  
 2.1 Aluminum Electrolytic Capacitors

This is represented by the code CE in the previous example.

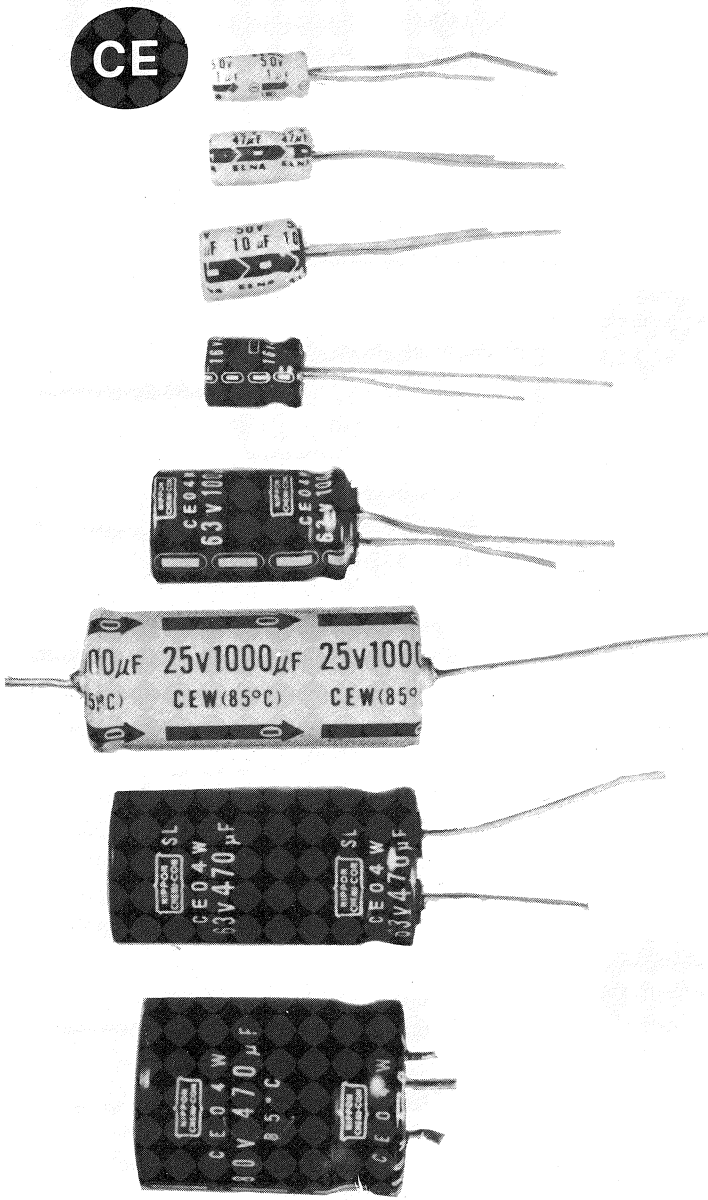

Fig. 3 Aluminum electrolytic capacitors for printed circuit boards

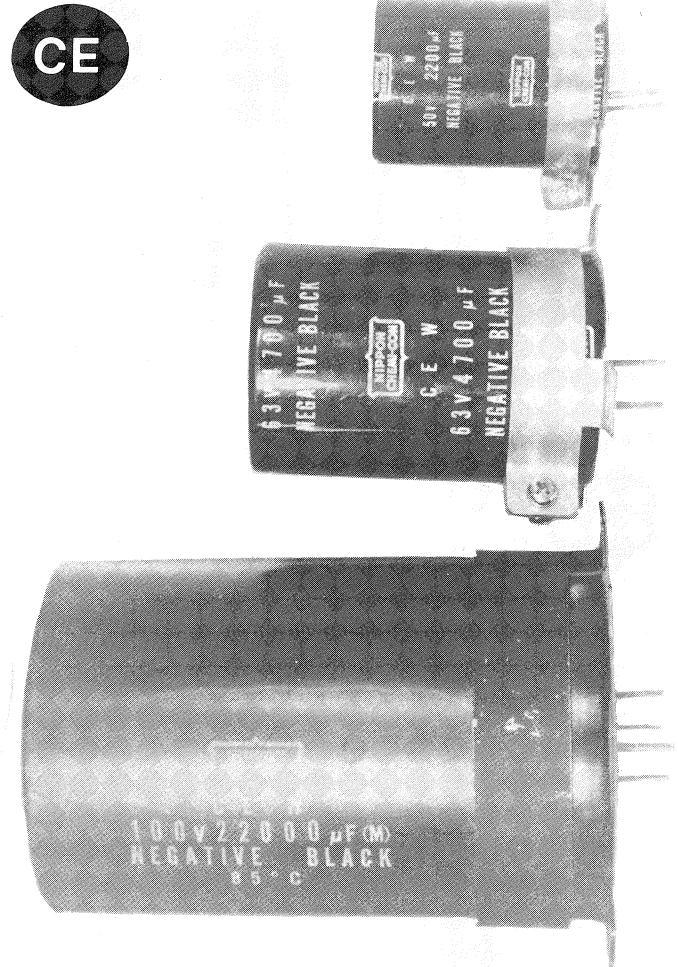

Fig. 4 Block electrolytic capacitors  
 Note that the Part No. differs from CR coding.

2.2 Solid Aluminum Electrolytic Capacitors for Coupling

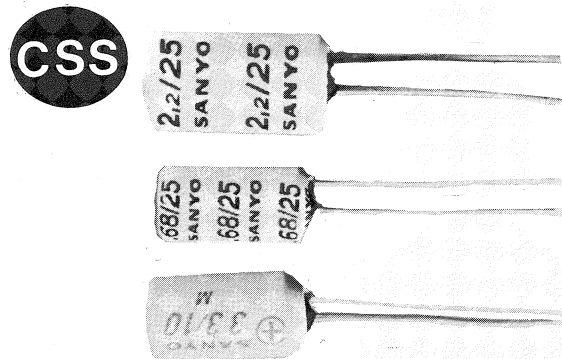

Fig. 5 Solid aluminum electrolytic capacitors

### 2.3 Solid Tantalum Electrolytic Capacitors

**CSZ**

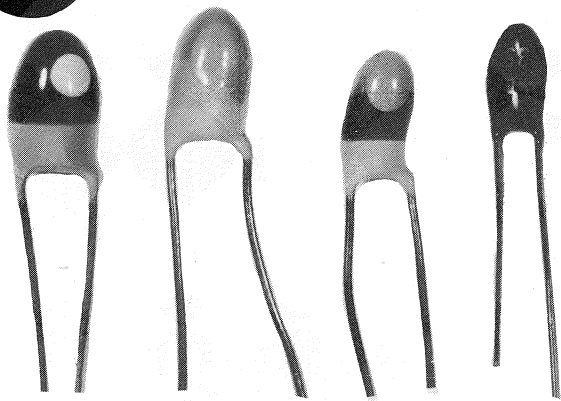

Fig. 6 Solid tantalum capacitors

### 2.4 Ceramic Capacitors

**CK/CC**

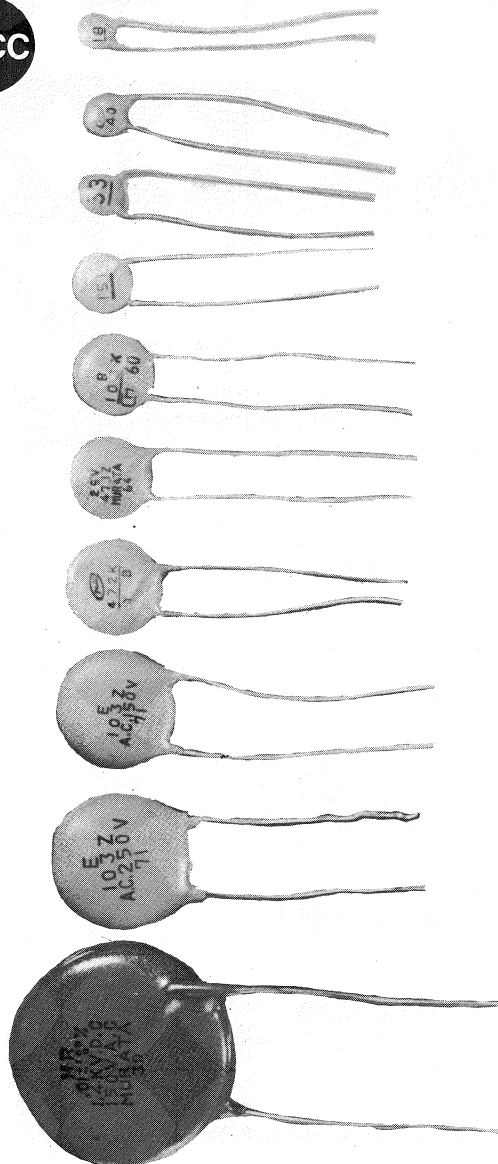

Fig. 7 Ceramic capacitors

### 2.5 Mylar\* Capacitors (Polyester Film Capacitors)

**CQM**

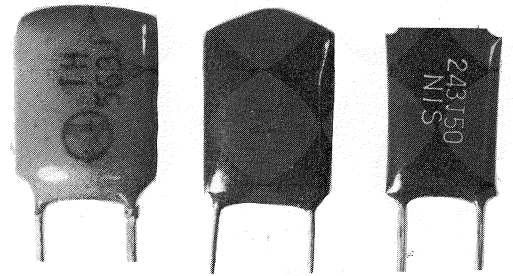

Fig. 8 Mylar capacitors  
Mylar is a registered brand name of Dupont Co. Ltd.

### 2.6 Polyestryrene Film Capacitors

**CQS**

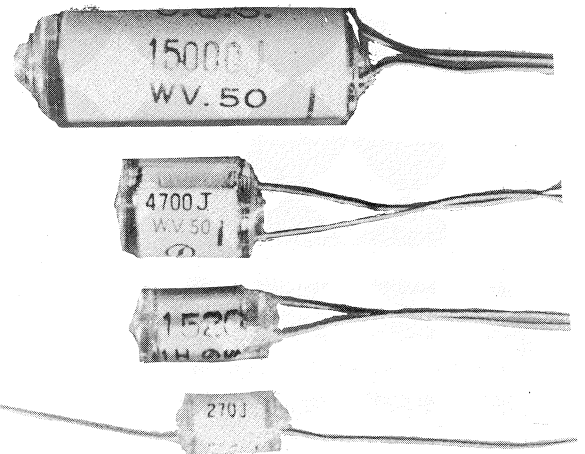

Fig. 9 Polyestryrene film capacitors

### 2.7 Ceramic Capacitors

**CG**

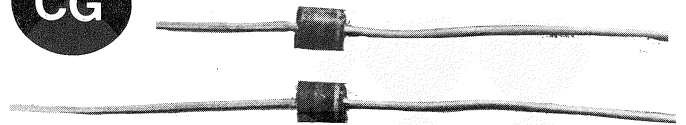

Fig. 10 Ceramic capacitors

### 2.8 Polyester Film Capacitors

**CQE**

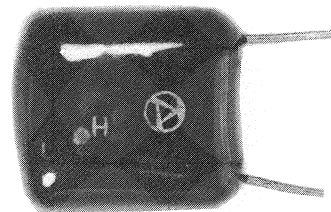

Fig. 11 Polyester film capacitors

### 2.9 Solid Aluminum Electrolytic Capacitors

This type of capacitor is not used today. Instead, the CSS type is used.

## 2.10 Mica Capacitors

Used before, but few of them are used today.



## 2.11 Polycarbonate Capacitors

Not used.



## 2.12 Oil-filled Paper Capacitors

Scarcely used for the products which utilize semi-conductors such as transistors. Parts No. for this is indicated by codes other than CR coding.

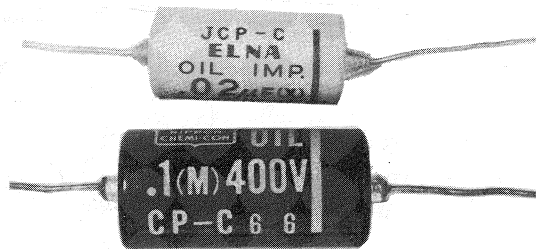

Fig. 12 Oil-filled paper capacitors

## 2.13 Polypropylene Film Capacitors

This is the most precise type of capacitor in current use and has a tolerance as low as  $\pm 1\%$ . For this reason, it is used in precision circuits.

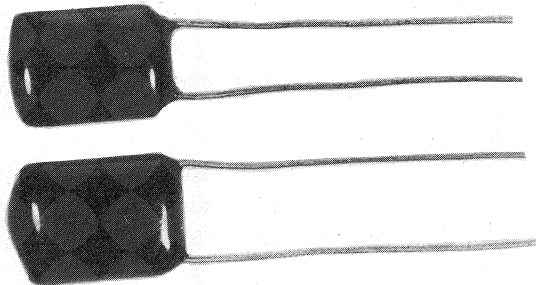

Fig. 13 Polypropylene film capacitors

## 2.14 Other Capacitors

### 2.14.1 MP Capacitors

Used in crossover networks of speaker systems and as condensive capacitors in tape decks. The Part No. differs from the CR code.

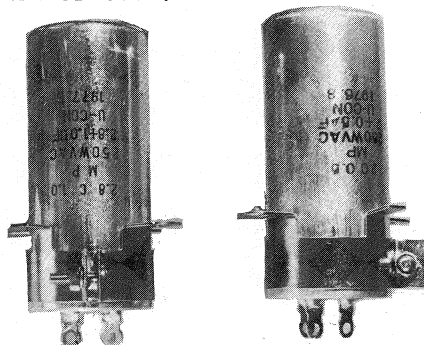

Fig. 14 MP capacitors used for crossover networks in speaker systems

### 2.14.2 Bipolar (BP) Electrolytic Capacitors

Used in crossover networks of speaker systems, this type of capacitor has been included in Pioneer's parts list from October, 1975.

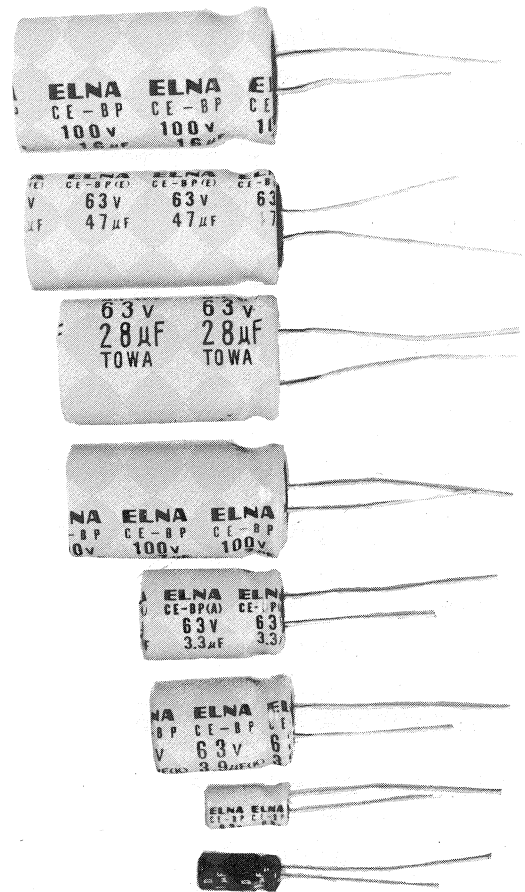

Fig. 15 Bipolar electrolytic capacitors

### 2.14.3 Metalized Film Capacitors

This is usually called an MF capacitor and is used in crossover networks of speaker systems. It is made by vapor deposition of aluminum on a polyester film and is similar to the CQE type. As from October, 1975, this type of capacitor has been included in Pioneer's parts list.

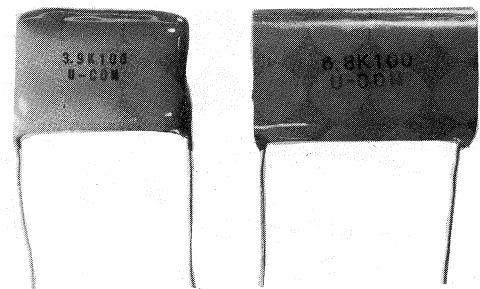

Fig. 16 Metalized film capacitors

### 3. Form

This is represented by one of the following letters of the alphabet:

- A: Terminals or leads on one end only
- B: Terminals or leads on both ends
- D: Disc type (ceramic, etc.)
- H: Terminals or leads on one end with insulator mount

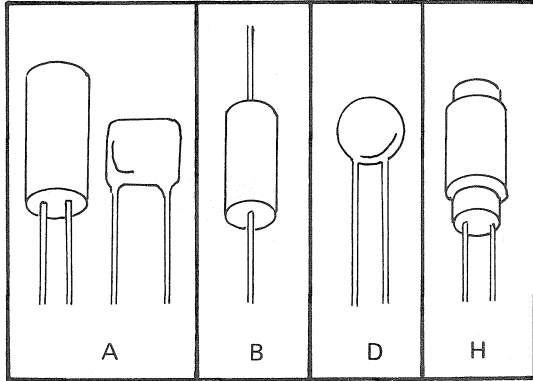

Fig. 17 Capacitors forms

### 4. Characteristics

The characteristics are represented by two letters of the alphabet, but only apply to ceramic (CK or CC) and electrolytic (CE) type capacitors.

#### 4.1 Ceramic Capacitors with High Dielectric Constant (CK)

CK-type capacitors are divided into the following five groups according to their capacitance variations within the operating temperature range of  $-25 \sim +85^\circ\text{C}$  for Y and  $-30 \sim +85^\circ\text{C}$  for B, using the capacitance at  $+20^\circ\text{C}$  as a reference.

Temp. range	Code	Capacitance variation range	Tolerance code
Y	A	Within $-5$ to $+5\%$	J, K
Y	B	Within $-10$ to $+10\%$	K
Y	D	Within $-30$ to $+20\%$	M
Y	F	Within $-80$ to $+30\%$	Z
B	C	Within $-30$ to $+30\%$	M, Z

Table 1 Characteristic code for CK-type capacitors

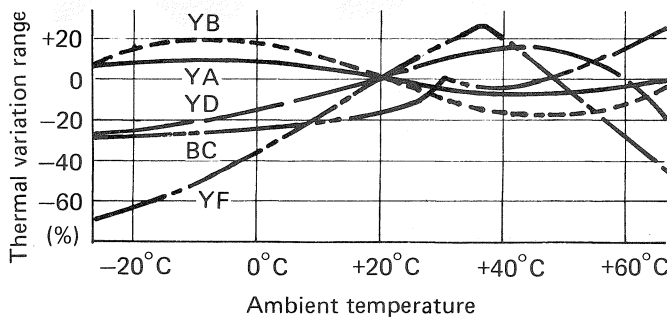

Fig. 18 Typical thermal characteristics curve for CK-type capacitors

### 4.2 Ceramic Capacitors for Thermal Compensation (CC)

The first letter of the code gives the temperature coefficient of the nominal capacitance, while the second indicates the capacitance tolerance. The codes for various sized CC-type capacitors are as follows:

2pF or less	CK, HK, LK, PK, RK, SK, TK, UK, SL
3pF	CJ, HK, LJ, PJ, RJ, SJ, TJ, UJ, SL
4 to 9pF	CH, HH, LH, PH, RH, SH, TH, UJ, SL
Above 10 to approx. 330pF	CG, HG, LG, PG, RG, VK, WK, LX, CH, HH, LH, PH, RH, SH, TH, UJ, SL

First code			Second code	
Code	Thermal coefficient PPM/ $^\circ\text{C}$	Color code	Code	Thermal coefficient tolerance PPM/ $^\circ\text{C}$
C	$\pm 0$	Black	G	$\pm 30$
H	$-30$	Brown	H	$\pm 60$
L	$-80$	Red	J	$\pm 120$
P	$-150$	Orange	K	$\pm 250$
R	$-220$	Yellow	L	$\pm 500$
S	$-330$	Green		
T	$-470$	Blue		
U	$-750$	Violet		
V	$-1,000$	V		
W	$-1,500$	W		
X	$-2,200$	X		
SL	$-1,000 \sim +350$	No color		

Table 2 Characteristics of CC-type capacitors

Note: 1. PPM represents  $10^{-6}$

2. Code SL indicates an ordinary capacitor for which no thermal coefficient is rated (capacitance variation range  $+4.5$  to  $-5\%$  at  $-25$  to  $+85^\circ\text{C}$ ).

3. Example UJ is for  $-750 \pm 120\text{PPM}/^\circ\text{C}$

### 4.3 Aluminum Electrolytic Capacitors (CE)

This type of capacitor, designed for very low leakage currents, is given an NL code and is covered by an orange tube.



## 5. Nominal Capacitance

The nominal capacitance is represented by a 3-digit figure followed by the unit  $\mu\text{F}$  for aluminum electrolytic capacitors and pF for other types. The first two digits give the significant value, while the third indicates the number of zeros that follow it. If a fraction is involved, the decimal point is represented by R.

Example  $2.2\mu\text{F}$  becomes 2R2

Depending on the rated tolerance of the capacitor, one of the codes for E-3 to E-24 series given in Table 3 is added to the significant digit. Note that aluminum electrolytic capacitors and ceramic capacitors smaller than 10pF are exceptions.

	Tolerance	Significant capacitance value
E-3	Z	10, 22, 47
E-6	M	10, 15, 22, 33, 47, 68
E-12	K	10, 12, 15, 18, 22, 27, 33, 39, 47, 56, 68, 82
E-24	J	10, 11, 12, 13, 15, 16, 18, 20, 22, 24, 27, 30, 33, 36, 39, 43, 47, 51, 56, 62, 68, 75, 82, 91
CE	P	10, 22, 33, 47
CC	C	0.5, 1, 2, 3
	D	4, 5, 6
	F	7, 8, 9, 10

**Table 3 Capacitance and tolerance codes**

Since non-polar aluminum electrolytic capacitors (CE) have Class M tolerance, the significant capacitance values for the E-6 series in Table 3 apply. Ceramic capacitors (CC) larger than 10pF are included in the E-6 to E-12 series.

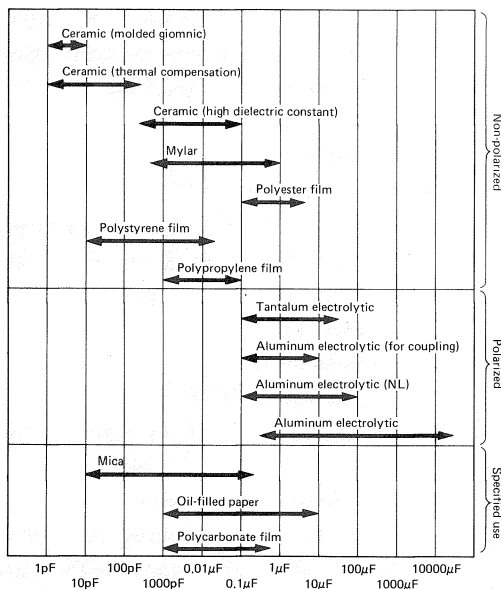

**Fig. 19 Capacitance ranges of capacitors**

## 6. Tolerance

Tolerance is indicated by a single letter and gives the range variation permitted beyond the nominal capacitance. The tolerance codes are given in Table 4.

Code	Tolerance	Remarks
C	$\pm 0.25\text{pF}$	Applies to 0.5 to 3pF CC-type
D	$\pm 0.5\text{pF}$	Applies to 4 to 6pF CC-type
E	$\pm 1\text{pF}$	Applies to 7 to 10pF CC-type
F	$\pm 1\%$	Possible with CQP-type
G	$\pm 2\%$	
J	$\pm 5\%$	
K	$\pm 10\%$	
M	$\pm 20\%$	
P	+50, -10%	Applies to CEA-type
X	+40, -20%	Applies to CSZ and CSS types (at present these capacitors are available with Class M tolerance)
Z	+80, -20%	Applies to 330 to 47,000pF CK-type

**Table 4 Allowable tolerance of capacitors**

## 7. Rated Working Voltage

This is indicated by a number only, the V being deleted, and represents the maximum DC voltage that can be supplied to the capacitor. Normally, it is limited to 50 volts for capacitors other than aluminum electrolytic types, while the maximum rated voltage for CE, CSS and CSZ types is 100V, 25V and 35V, respectively. Working voltages are standardized at 6, 10, 16, 25, 35, 50, 68, 80 and 100V.

## 8. Miscellaneous

This code is used only for indicating non-polar aluminum electrolytic capacitors and is identified by the letters NP.

## 9. Static Characteristics of Capacitors

Having dealt with the general characteristics of capacitors based on the CR code, now let's take a closer look at some of the more specific static characteristics that cover capacitance, tolerance, rated working voltage,  $\tan \delta$  or  $Q$  ( $Q=1/\tan \delta$ ), leakage current (L.C.) or insulation resistance (I.R.) and operating temperature range.

### 9.1 Capacitance Value (Refer to paragraph 5)

The capacitance ranges given in Fig. 9 are those in normal use. They reflect the characteristics of each capacitor, its dimensions and cost.

### 9.2 Tolerance (Refer to paragraph 6)

The minimum tolerance range for various types of capacitors having specific capacitances is given in Table 4. It must be noted here, though, that certain circuits require capacitors with particularly small tolerances.

### 9.3 Rated Working Voltage (Refer to paragraph 7)

Preferably, capacitors should be used at 80% or less of their rated working voltage. If the rated working voltage is exceeded, insulation breakdown or destruction may result. The rated working voltage is the sum of the DC and AC voltage components.

### 9.4 Tan $\delta$

The loss in a capacitor is expressed as a  $\tan \delta$  value, and the smaller it is, the better. Limitations in the  $\tan \delta$  value are determined by the type of dielectric material used and the structure of the capacitor itself. Some typical  $\tan \delta$  values are given in Table 5.

Type of capacitor	Tan $\delta$ value
CE (aluminum electrolytic capacitors)	0.1 to 0.4
CSS (aluminum electrolytic capacitors for coupling)	0.1 to 0.2
CSZ (tantalum electrolytic capacitors)	0.1 to 0.2
CQM (mylar film capacitors)	0.01 to 0.05
CQP (polypropylene film capacitors)	0.003 to 0.01
CQS (polystyrene film capacitors)	0.001 to 0.005
CK (ceramic capacitors)	0.03

**Table 5 Typical  $\tan \delta$  values for various types of capacitors**

The aluminum electrolytic capacitors in Table 5 indicate comparatively large  $\tan \delta$  values because of their greater capacity.

$\tan \delta$  can also be expressed by the equation  $\tan \delta = R \cdot \omega C$ .

### 9.5 Leakage Current (L.C.) of Insulation Resistance (I.R.)

When an aluminum electrolytic capacitor is used in a coupling or decoupling circuit, the noise generated in the circuit depends on the leakage current of the

capacitor. A smaller leakage current produces less noise.

Generally, the leakage current of an aluminum electrolytic capacitor is expressed by the following equation:

$$L.C.(\mu A) = K \cdot C \cdot V$$

where K: constant

C: capacitance ( $\mu F$ )

V: rated working voltage (V)

This value must be measured 30 seconds after turning the power on, and some typical values are given in Table 6.

Type of capacitor	Leakage current
CE (aluminum electrolytic capacitors)	0.03CV (5 minutes after being turned on)
CE-NL (low-leakage CE capacitors)	0.003CV
CSS (electrolytic capacitors for coupling)	0.003CV
CSZ (solid tantalum capacitors)	0.002CV

**Table 6 Typical leakage current values for electrolytic capacitors**

Now, let's examine the relationship between the leakage current of electrolytic capacitors and noise more closely.

A charge current flows when a voltage is supplied across a capacitor, and the amount of the current is expressed as:

Charge current = current determined by external factors + current by dielectric reduction effect due to ion current or dipole rotation + leakage current

$$I = \frac{V}{R} \epsilon^{-\frac{t}{CR}} + K_d \cdot CV \varphi(t) + K_r CV$$

where R: resistive component of capacitor  $R_s$  and resistive component (parallel resistance) of capacitor  $R_p$  (unit: ohm)

V: voltage (V)

C: capacitance ( $\mu F$ )

$K_d$ : constant ( $1/F\Omega$ )

$\varphi(t)$ : after effect function (a function of time determined by physical property of dielectric given as  $\varphi(t) = t^{-n}$ , and exponent n differs with each dielectric)

$K_r$ : constant ( $1/F\Omega$ )

The parallel resistance  $R_p$  of an electrolytic capacitor fluctuates with time and varies the charge current  $I$ , thereby producing noise. External factors cause the current to vary, reducing it exponentially with time. Noise also decreases with time. This initial value is included in the leakage current term. The third leakage current term has no relation to

time and represents a static condition. The relationship between the leakage current and time is illustrated in Fig. 20. For capacitors other than the electrolytic type, the leakage current (L.C.) is represented by the insulation resistance (*I.R.*). *I.R.* equals  $1/L.C.$

### 9.6 Operating Temperature Range

With the exception of the CQSA-type, all capacitors can be used in a temperature range of  $-25$  to  $+85^{\circ}\text{C}$ . The CQSA-type have a temperature range of  $-10$  to  $+70^{\circ}\text{C}$ .

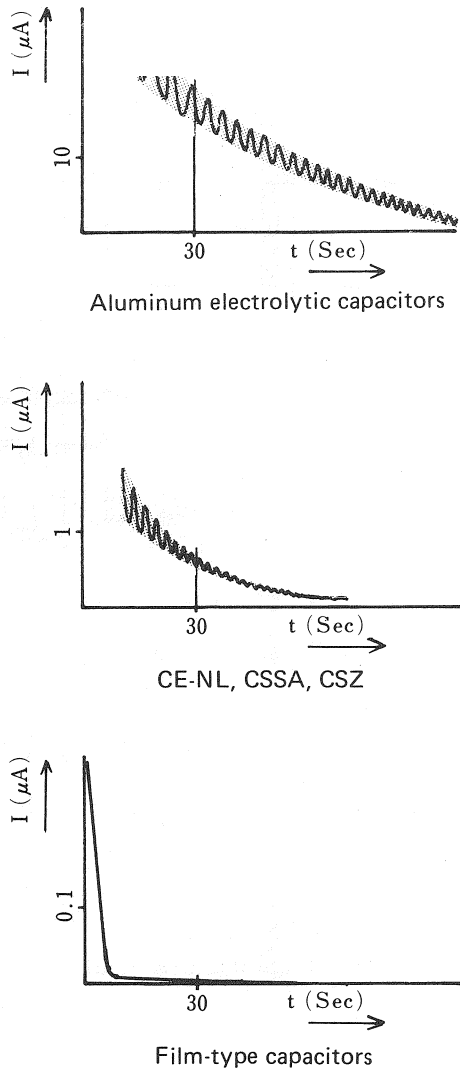

Fig. 20 Leakage current

## 10. Dynamic Characteristics of Capacitors

The term Dynamic Characteristics denotes a variation in the static characteristics under various ambient temperatures, signal frequencies and voltages.

### 10.1 Thermal Variations

#### 10.1.1 Capacitance Variations

Except for CCD and CKD type ceramic capacitors, thermal variation of capacitance is determined by

the type of dielectric used, and tends to be uniform in capacitors having the same dielectric.

By changing the mixture of the dielectric material, ceramic capacitors can be made to suit any desired thermal characteristics.

Typical thermal variation characteristics are shown in Fig. 21.

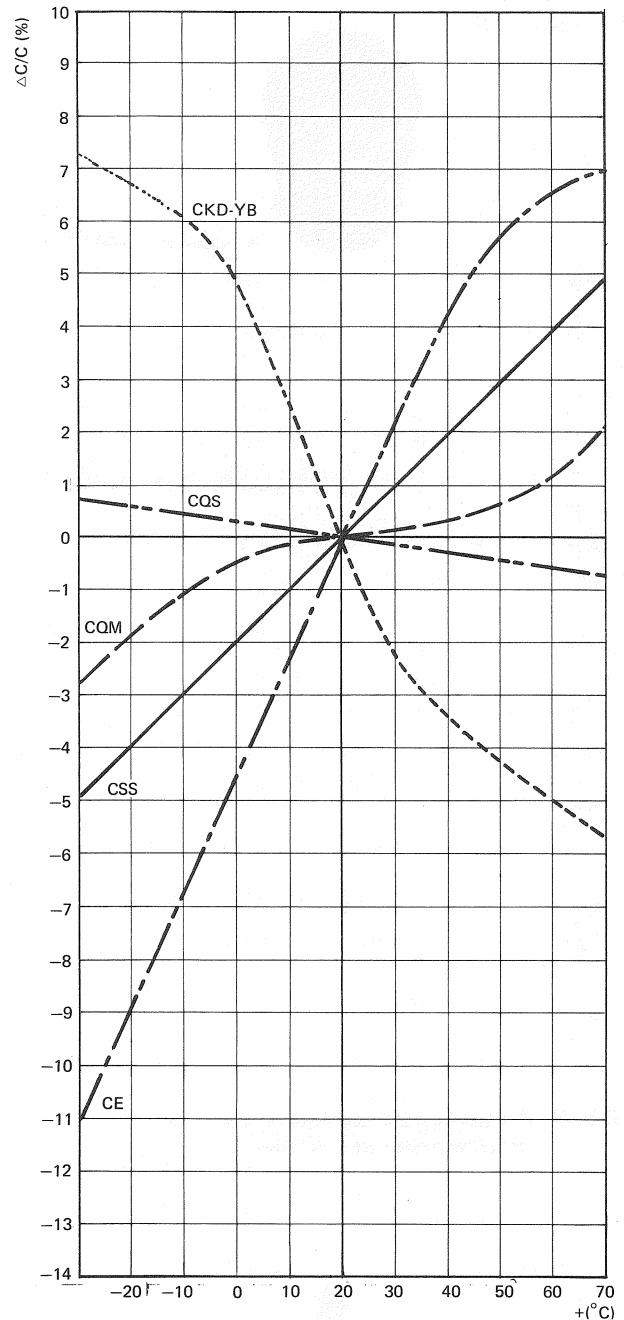

Fig. 21 Temperature VS capacitors' variation characteristics of capacitors

Class I Class II Item		CE		CS		CQ			CKD	
		Ordinary	NL	CSS(A)	CSZ(A)	CQM(A)	CQS(A)	CQP(A)	YA	YB
High temperature, loaded	Cap.	±25% or less of initial value	±25% or less of initial value	±10% or less of initial value	±10% or less of initial value	±8% or less of initial value	Less than ±3% of initial value or ±1pF, whichever is the larger	±3% or less of initial value	±5% or less of initial value	±10% or less of initial value
	L.C.	Within the specified limit	Within the specified limit	Twice the rated value or less	Twice the rated value or less	I.R. 2.7 × 10 <sup>3</sup> MΩ or more	I.R. 2.25 × 10 <sup>4</sup> MΩ or more	I.R. 1 × 10 <sup>5</sup> MΩ or more	I.R. 1 × 10 <sup>3</sup> MΩ or more	I.R. 1 × 10 <sup>3</sup> MΩ or more
	tan δ.	1.5 times of the rated value or less	1.5 times of the rated value or less	1.5 times of the rated value or less	1.5 times of the rated value or less	1.1% or less	0.11% or less (0.23% or less for capacitors smaller than 330pF)	Within the specified limit	3% or less	4% or less
High temperature, unloaded	Cap.	±20% or less of initial value	±20% or less of initial value	±5% or less of initial value	±10% or less of initial value	±8% or less of initial value	Less than ±3% of initial value or ±1pF, whichever is the larger	±3% or less of initial value	±5% or less of initial value	±10% or less of initial value
	L.C.	Within the specified limit	3 times of the rated value or less	1.25 times of the rated value or less	Twice the rated value or less	I.R. 2.7 × 10 <sup>3</sup> MΩ or more	I.R. 2.25 × 10 <sup>4</sup> MΩ or more	I.R. 1 × 10 <sup>5</sup> MΩ or more	I.R. 1 × 10 <sup>3</sup> MΩ or more	I.R. 1 × 10 <sup>3</sup> MΩ or more
	tan δ.	1.5 times of the rated value or less	1.5 times of the rated value or less	1.5 times of the rated value or less	1.5 times of the rated value or less	1.1% or less	0.11% or less (0.23% or less for capacitors smaller than 330pF)	Within the specified limit	3% or less	4% or less
High moisture, loaded	Cap.	±15% or less of initial value	±15% or less of initial value	±5% or less of initial value	±10% or less of initial value	±10% or less of initial value	Less than ±5% of initial value or ±1pF, whichever is the larger	±3% or less of initial value	±5% or less of initial value	±10% or less of initial value
	L.C.	Within the specified limit	Within the limit	1.25 times of the rated value or less	1.25 times of the rated value or less	I.R. 4.5 × 10 <sup>3</sup> MΩ or more	I.R. 1.35 × 10 <sup>4</sup> MΩ or more	I.R. 1 × 10 <sup>5</sup> MΩ or more	I.R. 1 × 10 <sup>3</sup> MΩ or more	I.R. 1 × 10 <sup>3</sup> MΩ or more
	tan δ.	Within the specified limit	Within the specified limit	Within the specified limit	Within the specified limit	1.2% or less	0.11% or less (0.23% or less for capacitors smaller than 330pF)	Within the specified limit	3% or less	5% or less
High moisture, unloaded	Cap.	±15% or less of initial value	±15% or less of initial value	±5% or less of initial value	±10% or less of initial value	±10% or less of initial value	Less than ±5% of initial value or ±1pF, whichever is the larger	±3% or less of initial value	±5% or less of initial value	±10% or less of initial value
	L.C.	Within the specified limit	Within the specified limit	1.25 times of the rated value or less	1.25 times of the rated value or less	I.R. 4.5 × 10 <sup>3</sup> MΩ or more	I.R. 1.35 × 10 <sup>4</sup> MΩ or more	I.R. 1 × 10 <sup>5</sup> MΩ or more	I.R. 1 × 10 <sup>3</sup> MΩ or more	I.R. 1 × 10 <sup>3</sup> MΩ or more
	tan δ.	Within the specified limit	Within the specified limit	Within the specified limit	Within the specified limit	1.2% or less	0.11% or less (0.23% or less for capacitors smaller than 330pF)	Within the specified limit	3% or less	5% or less
Left in the air	Cap.	Within the specified limit	Within the specified limit	Within the specified limit	Within the specified limit	Within the specified limit	Within the specified limit	Within the specified limit	Within the specified limit	Within the specified limit
	L.C.	Within the specified limit	Within the specified limit	Within the specified limit	Within the specified limit	Within the specified limit	Within the specified limit	Within the specified limit	Within the specified limit	Within the specified limit
	tan δ.	Within the specified limit	Within the specified limit	Within the specified limit	Within the specified limit	Within the specified limit	Within the specified limit	Within the specified limit	Within the specified limit	Within the specified limit

Table 7 Life characteristics of capacitors

## 10.2 Frequency Variations

### 10.2.1 Capacitance Variations

This varies depending on the kind and structure of the dielectric and the method of leading out the capacitor leads. (Please note that some capacitors have 3 or 4 leads to obtain better frequency characteristics. See the photo below.) In the case of small capacitors, the variations are small but the larger electrolytic capacitors show comparably large capacitance variations. Fig. 22 shows the typical variation characteristics.

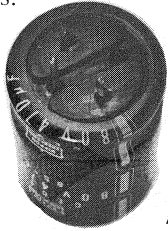

A capacitor with 3 leads.

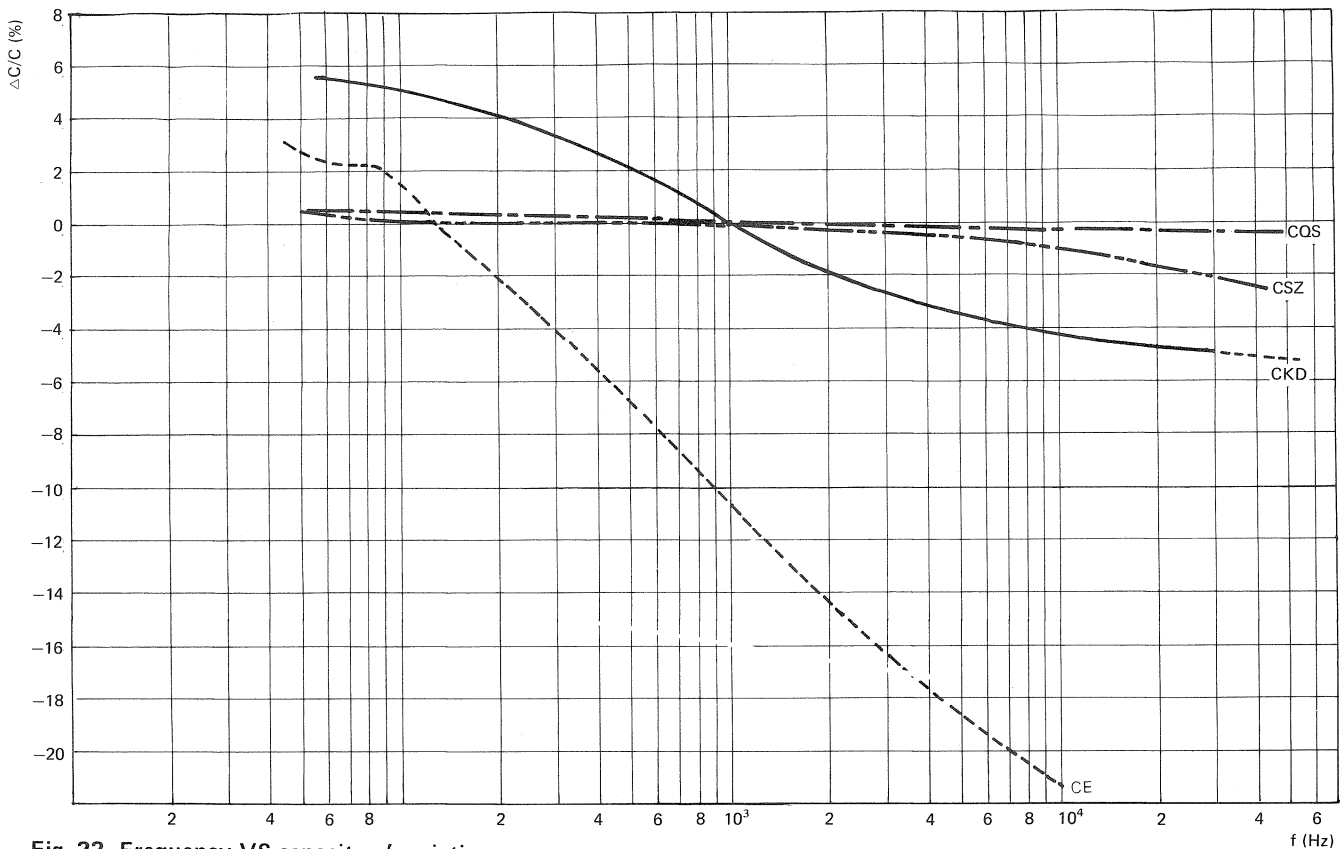

Fig. 22 Frequency VS capacitors' variation characteristics of capacitors

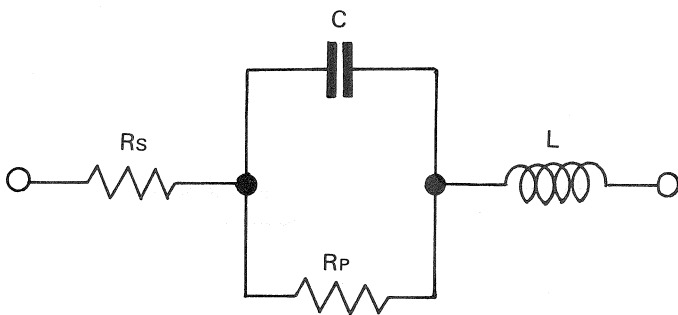

Fig. 23 Equivalent circuit of capacitors

### 10.2.2 Impedance Variations and Usable Frequency Range

Fig. 23 shows the equivalent capacitor circuit and its impedance characteristics are shown in Fig. 24. In Fig. 24, phasing is 0 at  $f_0$ , and at frequencies above  $f_0$ , the capacitor functions as an inductor (coil). At  $f_0$ , the operating frequency of the capacitor is limited. Recent reports concerning the tonal quality of audio amplifiers reflects the difference in the impedance curves of the capacitors used. The frequency/impedance relationship of aluminum electrolytic capacitors is shown in Fig. 25.

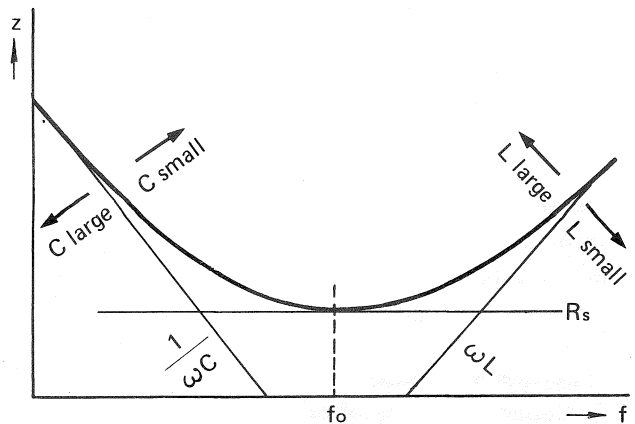

Fig. 24 Frequency/Impedance relationship of capacitors

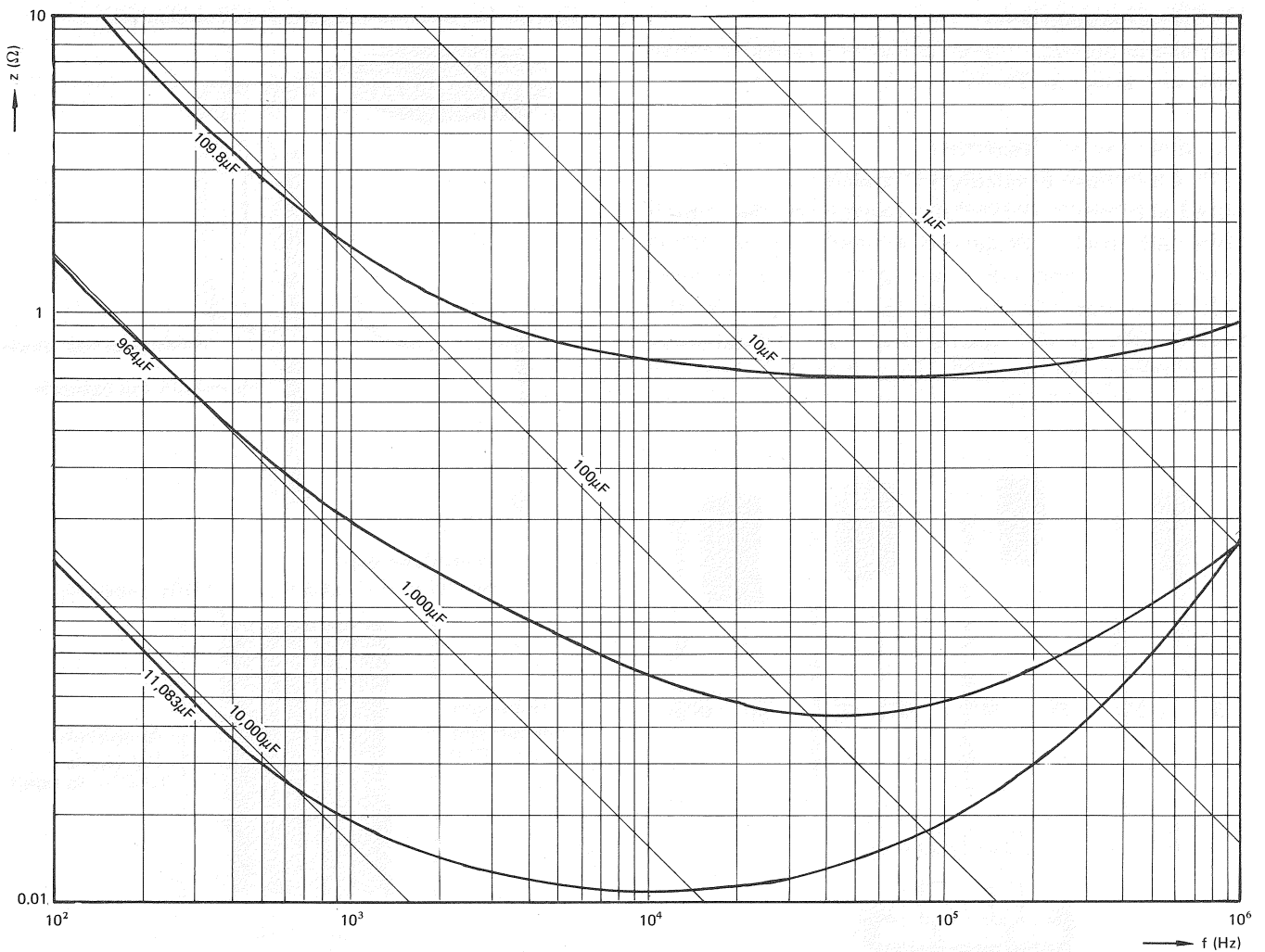

Fig. 25 Frequency VS impedance characteristics of aluminum electrolytic capacitors

### 10.3 Voltage Variations

#### 10.3.1 Capacitance Variations

Within their rated operating voltage, electrolytic capacitors produce no variation in capacitance, but ceramic capacitors (CK) with a high dielectric coefficient produce a variation of approximately 2% when AC and DC voltages are superimposed. This tendency, however, cannot be found in other capacitors, which is probably due to their dielectric properties.

#### 10.3.2 Leakage Current

The leakage current of electrolytic capacitors is proportional to the voltage supplied. Within the rated working voltage range, the insulation resistance variation is negligible.

## 11. Life Characteristics

Life characteristic ratings for various types of capacitors are given in Table 7.

## 12. Structure of Capacitors

### 12.1 Aluminum Electrolytic Capacitors

On all aluminum electrolytic capacitors, the capacitance and rated working voltage markings are digital. Both the NL and NP type capacitors are covered with an orange sleeve, and the NP type are also marked BP. In the case of large block capacitors, the marking is changed to a Part Number, for example, ACH-000-0.

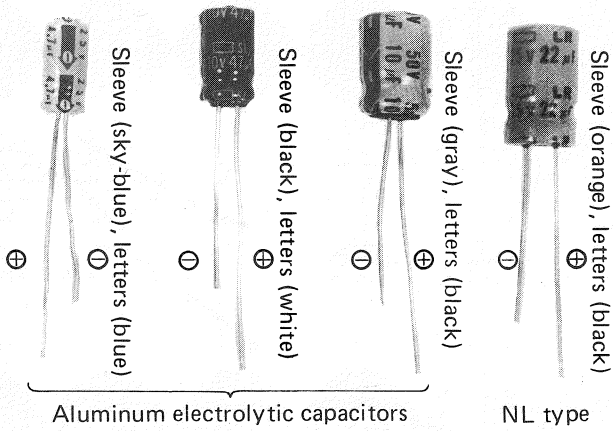

13

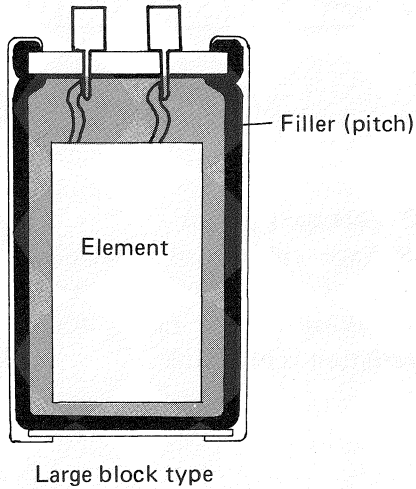

Large block type

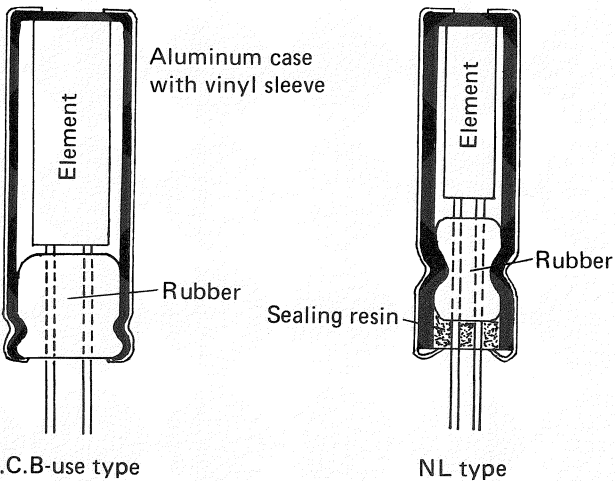

P.C.B-use type

NL type

Electrolytic paper impregnated with electrolyte

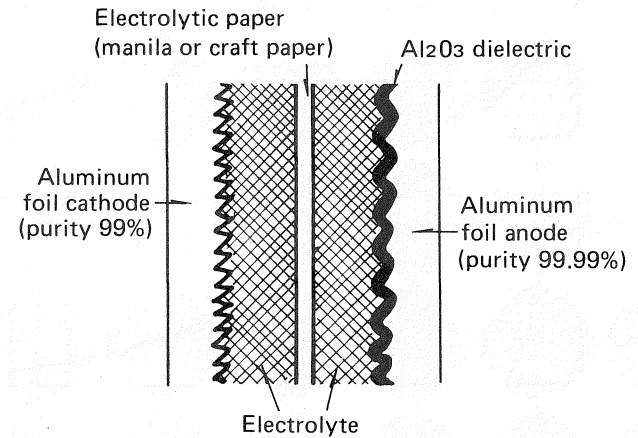
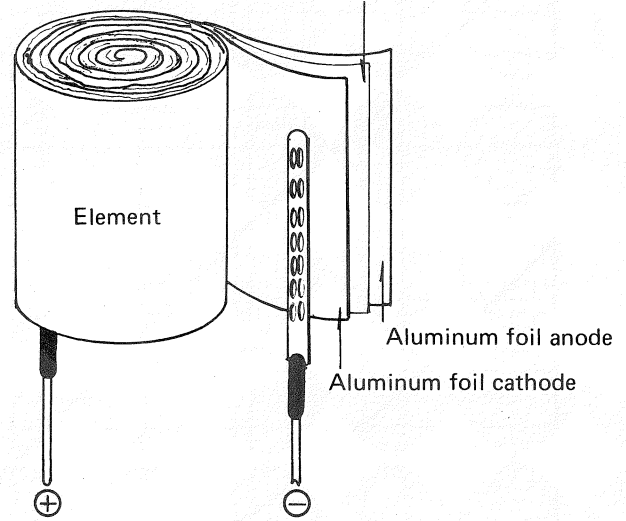

(An ethylene glycol glycerine solution in boric ammonia or H<sub>2</sub>O that does not corrode aluminum)

Fig. 26 Structure of aluminum electrolytic capacitors

## 12.2 Aluminum Electrolytic Capacitors (CSS) for Coupling

These feature black digital capacitance and tolerance markings on a sky-blue sleeve. The positive lead is located in the center at the bottom.

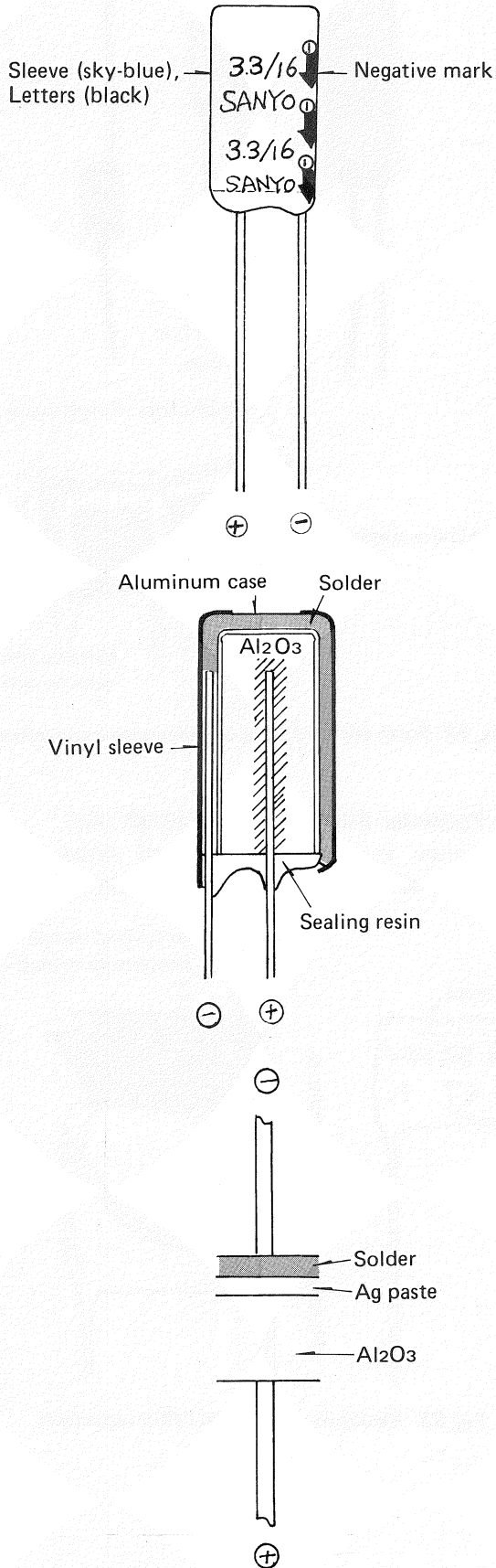

Fig. 27 Aluminum electrolytic capacitors for coupling

## 12.3 Solid Tantalum Capacitors (CSZ)

Capacitance and rated working voltage are either digital or color coded. As shown in Fig. 28, the color coding consists of a polarity and multiplier dot, two bands for the significant 2-digit values and a third band for the rated working voltage.

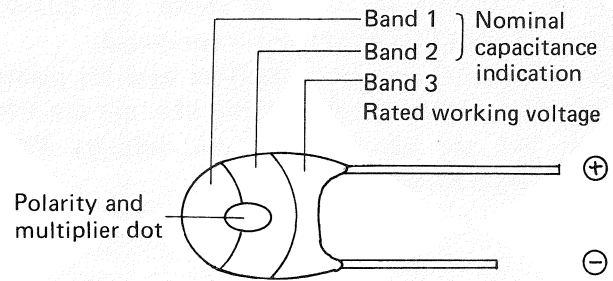

Fig. 28 Color coding of solid tantalum capacitors

Band 1 and 2 (Significant value)		Dot (Multiplier)		Band 3 (Rated working voltage)	
Black	0	Black	x1	Yellow	6
Brown	1	Brown	x10	Black	10
Red	2	Gray	x0.01	Green	16
Orange	3	White	x0.1	Gray	25
Yellow	4			Pink	35
Green	5				
Blue	6				
Violet	7				
Gray	8				
White	9				

Table 8 Color coding chart

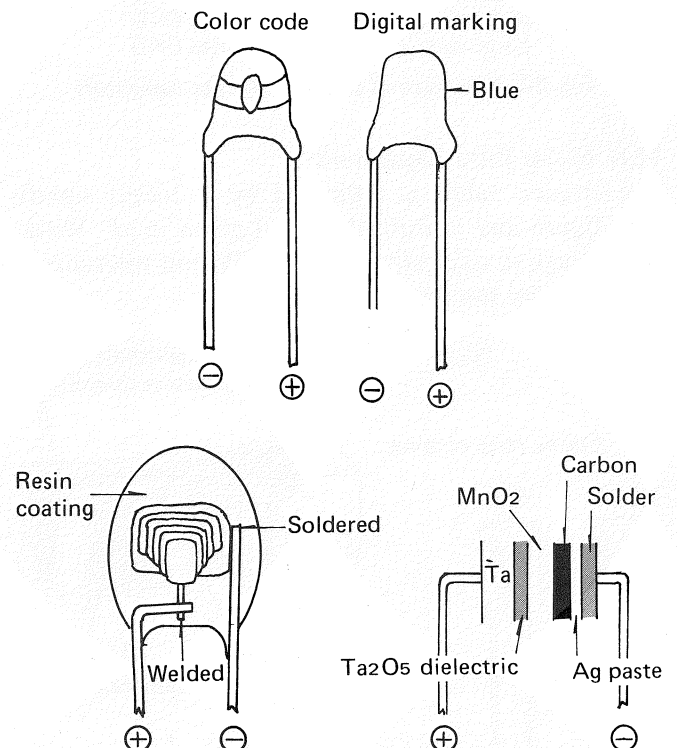

Fig. 29 Structure of solid tantalum capacitors



### 12.4 Ceramic Capacitors (CK and CC)

Normally, capacitance value is indicated by a 2-digit significant figure and a multiplier, and given in pF. Most ceramic capacitors are rated at 50V, which is indicated by underlining, for example, 151. The CK and CC types are distinguished from each other by their capacitance values. The CC-type are less than 301, the CK-type are 331 and above. The characteristics of the CC-type are also color-coded.

High voltage AC ceramic capacitors used for power switch noise killer circuits or the like, are not CR-coded, but are identified by an ordinary Parts Number, such as, ACG-000-0.

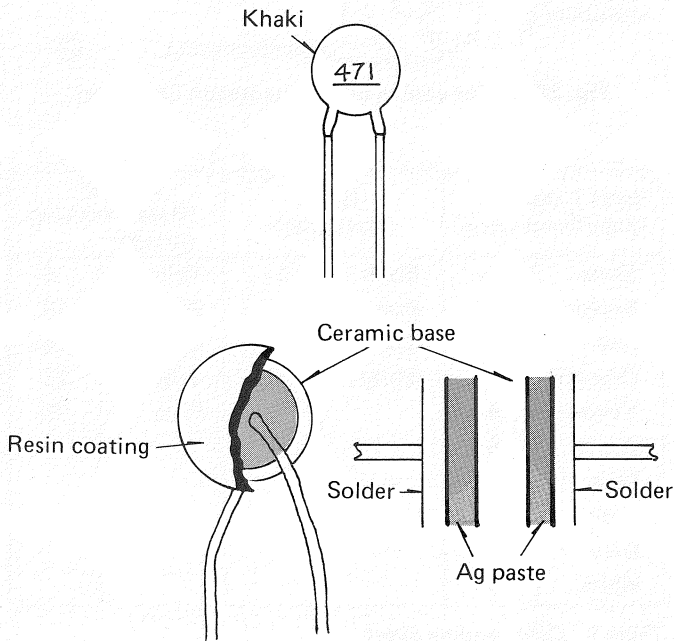

Major ceramic components  
 Small capacitance MgTiO<sub>3</sub> series CCD  
 Medium capacitance TiO<sub>2</sub> series CCD  
 Large capacitance BaTiO<sub>3</sub> series CKD

Fig. 30 Structure of CC and CK type capacitors

### 12.5 Mylar Film Capacitors

Capacitance value is indicated by a 2-digit significant figure and a multiplier, and given in pF. Working voltage is normally rated at 50V and tolerance is identified by the letter J.

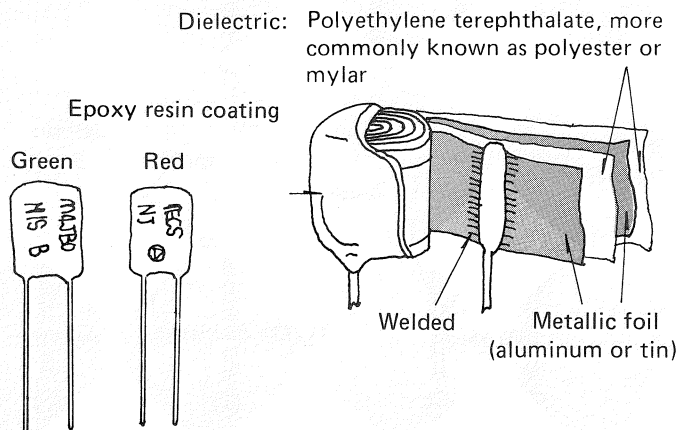

Fig. 31 Structure of mylar film capacitors

### 12.6 Polystyrene Film Capacitors (A) (B) (H)

Capacitance in pF, tolerance and rated working voltage are all indicated by digital markings.

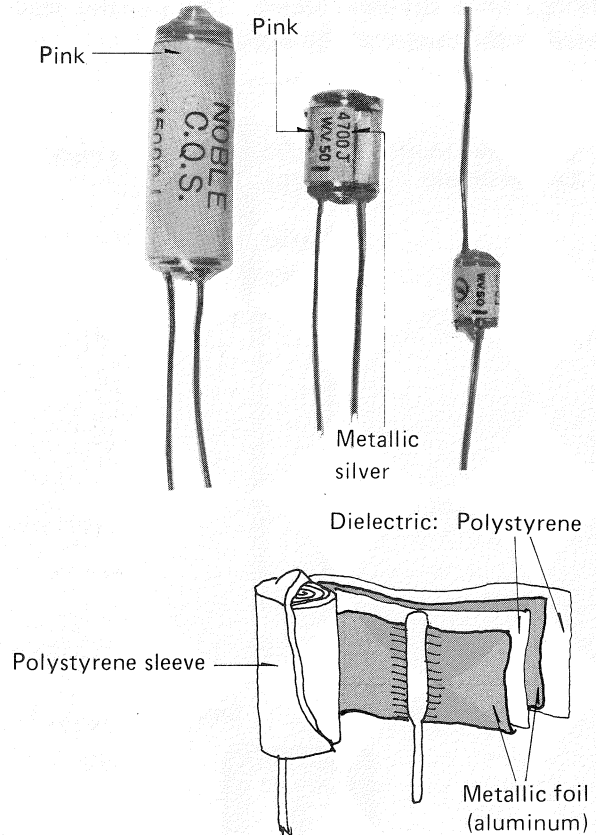

Fig. 32 Form and structure of polystyrene capacitors

### 12.7 Polyester Film Capacitors (CQF (A))

Capacitance in  $\mu$ F, tolerance and rated working voltage are all indicated by digital markings.

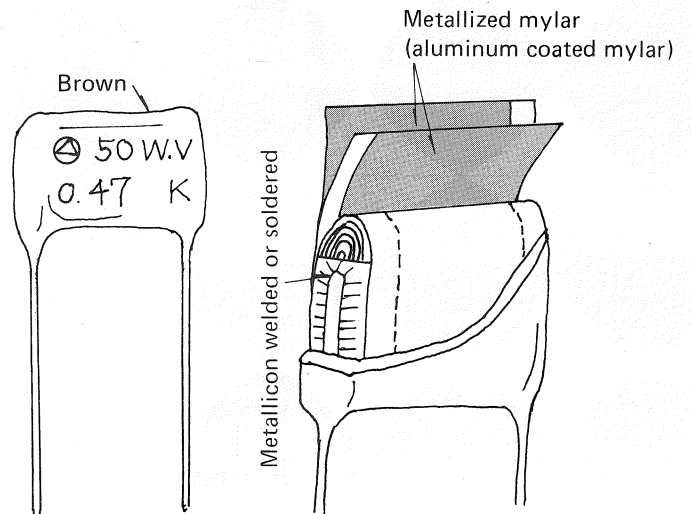

Fig. 33 Structure of polyester film capacitors

### 12.8 Polypropylene Film Capacitors

Markings that are currently used to identify polypropylene film capacitors are distinguished from the mylar type by a blue resin coating. Mylar film capacitors have green or red coatings. Capacitance values are given in pF and identified by a 3-digit figure consisting of two significant digits and a multiplier. Tolerance and rated working voltage are identified by F, G or J, and 100 markings, respectively.

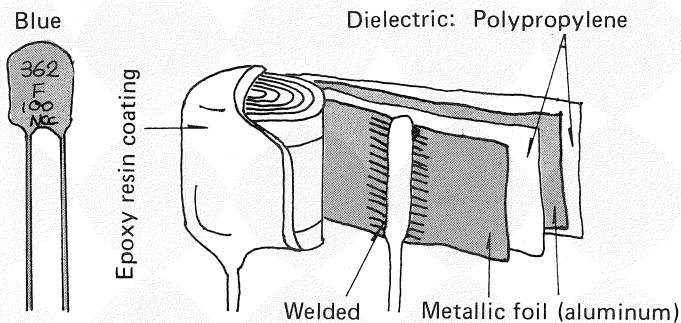

Fig. 34 Structure of polypropylene film capacitors

### 13. Major Applications of Capacitors

Capacitors have a wide range of applications in electronic circuit design. Some of the more major applications are listed below.

#### 13.1 CEA or ACH (aluminum electrolytic capacitors)

- Power supply smoothing
- Power supply decoupling
- Large capacity decoupling
- Signal coupling where capacitor noise is not a major concern
- Time constant element in protection circuits, etc.

#### 13.2 CEA-NL (low-leakage CEA)

- Audio-coupling (mainly in output circuits)
- MPX coupling circuits

#### 13.3 CSS (aluminum electrolytic capacitors for coupling)

- Audio-coupling circuits
- MPX coupling circuits

#### 13.4 CSZ (solid tantalum capacitors)

- Audio-coupling circuits
- Tuner signal meter time constant circuits

#### 13.5 CCD (thermal compensation ceramic capacitors)

- RF, tuning and audio phase-compensation circuits
- Anti-buzz circuits

#### 13.6 CKD (high dielectric coefficient ceramic capacitors)

- High-frequency bypass circuits
- High-frequency decoupling circuits
- Audio phase-compensation circuits
- Power amplifier power supply (HF bypassing)
- Input ground to chassis (HF bypassing)
- Power switch noise killer
- Power rectifier noise suppression

#### 13.7 CQMA (mylar film capacitors)

- Filter/equalizer elements
- Tone control elements
- Power amplifier HF phase compensation
- HF circuit bypassing
- HF circuit decoupling
- AF power supply HF bypassing

#### 13.8 CGB (molded gimononic capacitors)

- HF coupling circuits

#### 13.9 COEA (polyester film capacitors)

- Audio coupling circuits (input circuits)

#### 13.10 CQS (polystyrene film capacitors)

- Equalizer elements
- MPX PLL free-running frequency adjustment
- Tone control elements
- AM local oscillator coupling
- FM tuner deemphasis elements

#### 13.11 CQP (polypropylene film capacitors)

- Equalizer elements
- FM tuner deemphasis elements

---

# New Products (2)

---

## PL-570

---



17

Since its inception in June 1976, Pioneer's trend-setting PL-550 quartz-PLL direct-drive turntable has taken the market by storm with its matchless performance and uncompromising quality. Now, one and a half years later, more models such as the PL-570, PL-570X and PL-590 have been introduced which are also winning worldwide acclaim.

However, despite its success, the quartz-PLL direct-drive turntable has presented certain problems to the service engineer due to its high degree of sophistication and the fact that no-one has yet had an opportunity to repair one. At least this is the general consensus judging by reports received from overseas. In this issue, therefore, we are going to look into the

principle of the quartz-PLL direct-drive system and see what makes models like the PL-570, for example, tick.

Until now, digital circuits were of little concern to the audio engineer. But the introduction of complicated digital electronic techniques and the incorporation of large-scale ICs into the latest quartz-PLL direct-drive turntable designs has changed all that.

What follows, then, is a detailed report on the operating principle of the quartz-PLL direct-drive turntable, together with troubleshooting steps to assist field servicing of this new generation of turntables.

Schematic diagrams, P.C. board patterns and parts list

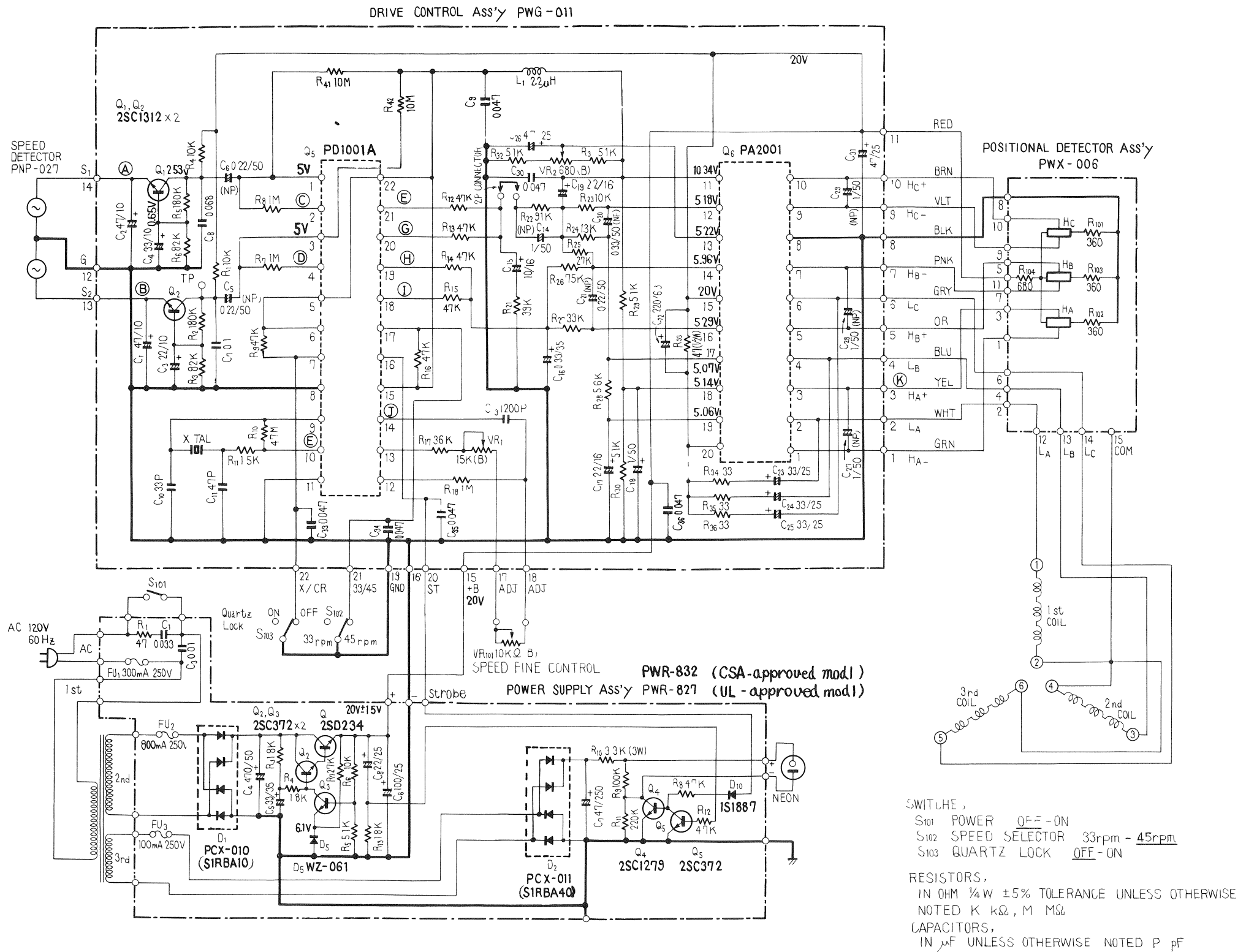
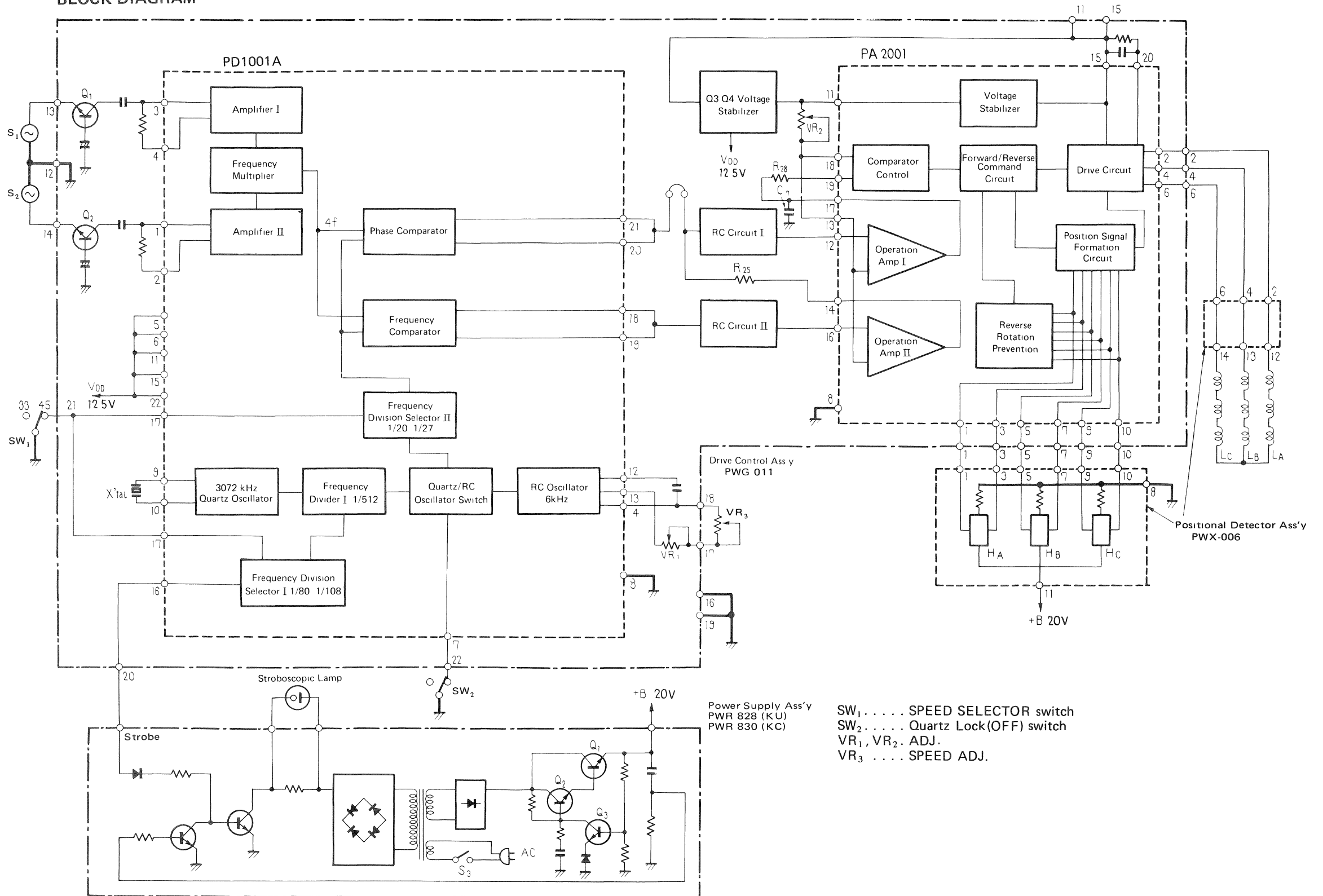

Fig. 1

Operating principles, circuit description

BLOCK DIAGRAM



Power Supply Ass'y  
PWR 828 (KU)  
PWR 830 (KC)

SW<sub>1</sub> . . . . . SPEED SELECTOR switch  
SW<sub>2</sub> . . . . . Quartz Lock(OFF) switch  
VR<sub>1</sub>, VR<sub>2</sub>. ADJ.  
VR<sub>3</sub> . . . . . SPEED ADJ.

Fig. 2

## 1. Operating Principle of the Quartz-PLL DD Motor

In principle, the PLL (Phase-Locked Loop) control system used in the PL-570 is almost identical to that employed in an FM-MPX demodulator or CD-4 demodulator. The only difference is that the PLL system used in the turntable has a mechanical rotating unit (the motor) in the loop, and the output is a mechanical movement.

The PLL-controlled motor contains a built-in AC generator.

An AC signal of which the frequency is proportional to the rotating speed is generated and fed back to the control block.

The control block is composed of a frequency comparator and phase comparator, and they compare the frequency and phase of the generated signal with the reference signal.

Any deviation from the rated rotational speed results in an error in the frequency and phase.

The comparators detect the difference in the frequency and phase, and give an order to the drive circuit to restore the rotation to its rated speed. Both phase and frequency control together play a signifi-

cant role in controlling motor speed, since the control loop effectively counteracts any error between the reference signal and the generated signal.

From this, it is easy to see how the stability of the motor speed is dependent on the stability of the reference signal, and as long as the reference signal remains stable, so will the motor speed.

In actual fact, the motor speed is controlled moment-by-moment. Thus, not only is the rotational speed highly stable, but, wow and flutter are reduced to absolute minimum. This unbelievably high stability is made possible by the use of a quartz oscillator, the very same that is used to maintain accuracy in the latest quartz watches.

As a result, the quartz-PLL direct-drive motor offers matchless performance with a speed error of 0%, wow and flutter of 0.0025% or less, hourly drift of 0.0003%/H or less and thermal drift of 0.00004°C or less. What's more, against any load variation below a stylus pressure of 1.2g, the quartz-PLL direct-drive motor maintains a 0% speed fluctuation. And that is far beyond the capability of any other motor.

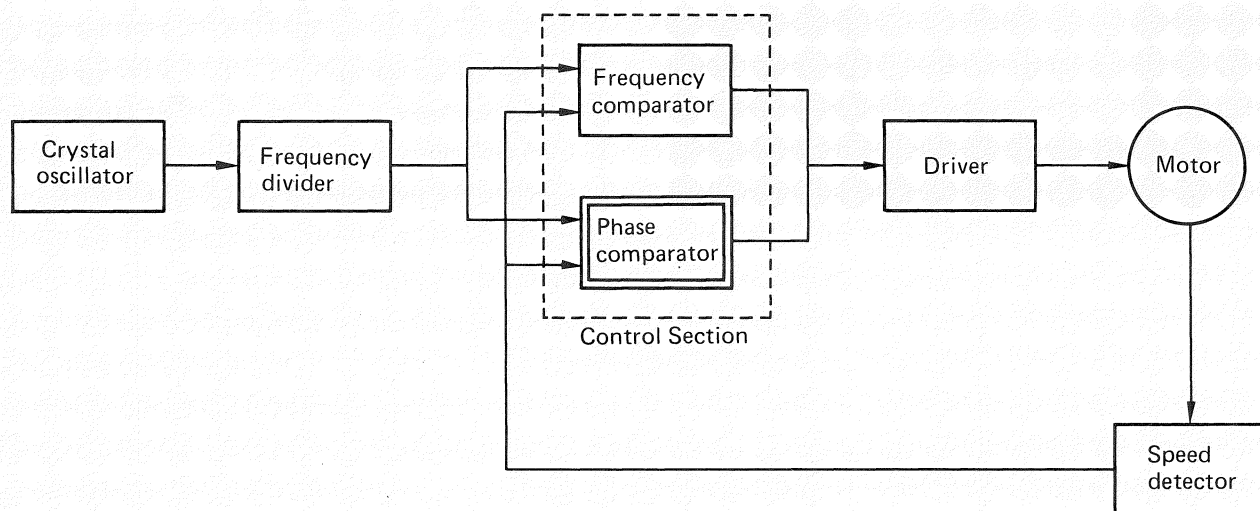

Fig. 3 Block diagram of quartz-PLL direct-drive motor

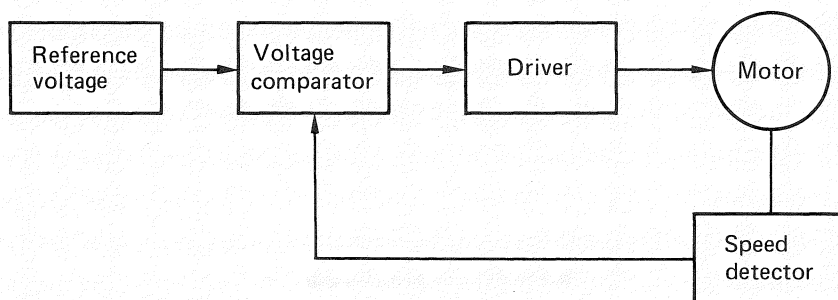

Fig. 4 Block diagram of E-servo motor

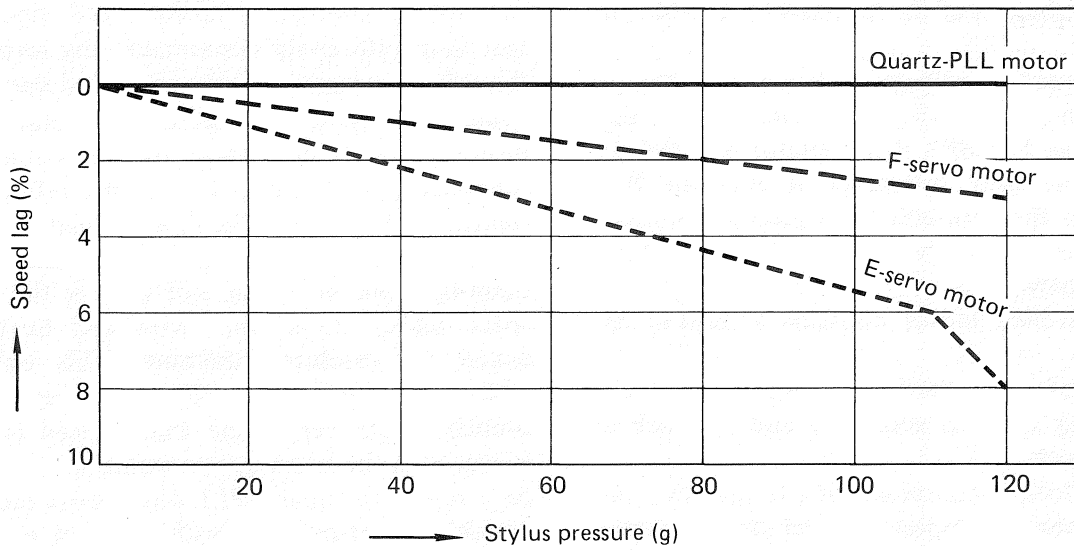
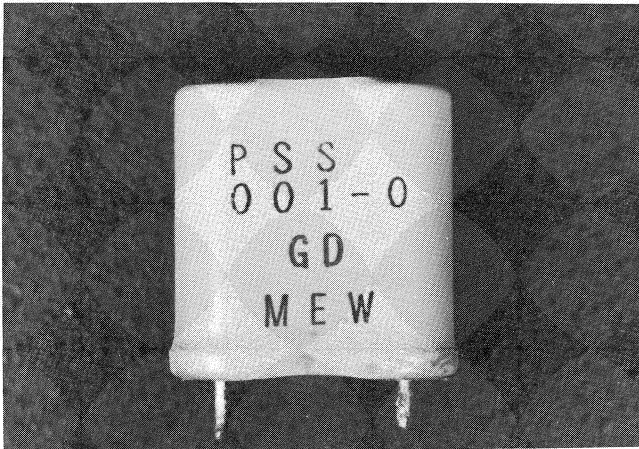

Fig. 5 Lowering of speed with stylus pressure



**Direct-drive turntable drift characteristics**

	Thermal drift (%/°C)	Time drift (%/H)
Quartz-PLL	0.00004	0.0003
F-servo	0.02	0.07
E-servo	0.025	0.20

**Frequency accuracy of oscillators**

Crystal (quartz) oscillators	$10^{-7}$ (0.00001%)
Tuning fork oscillator	$10^{-6}$ (0.0001%)
Piezo oscillator	$10^{-5}$ (0.001%)
CR oscillator	$10^{-4}$ (0.01%)
Commercial power source	$10^{-3}$ (0.1%)

## 2. Summary of Operation

The block diagram of an actual PLL circuit is shown in Fig. 2, but to make it easier to understand the principle of how a quartz-PLL direct-drive motor

works, a simplified block diagram is illustrated in Fig. 3, and that of the PL-570 control circuit is represented in Fig. 6.

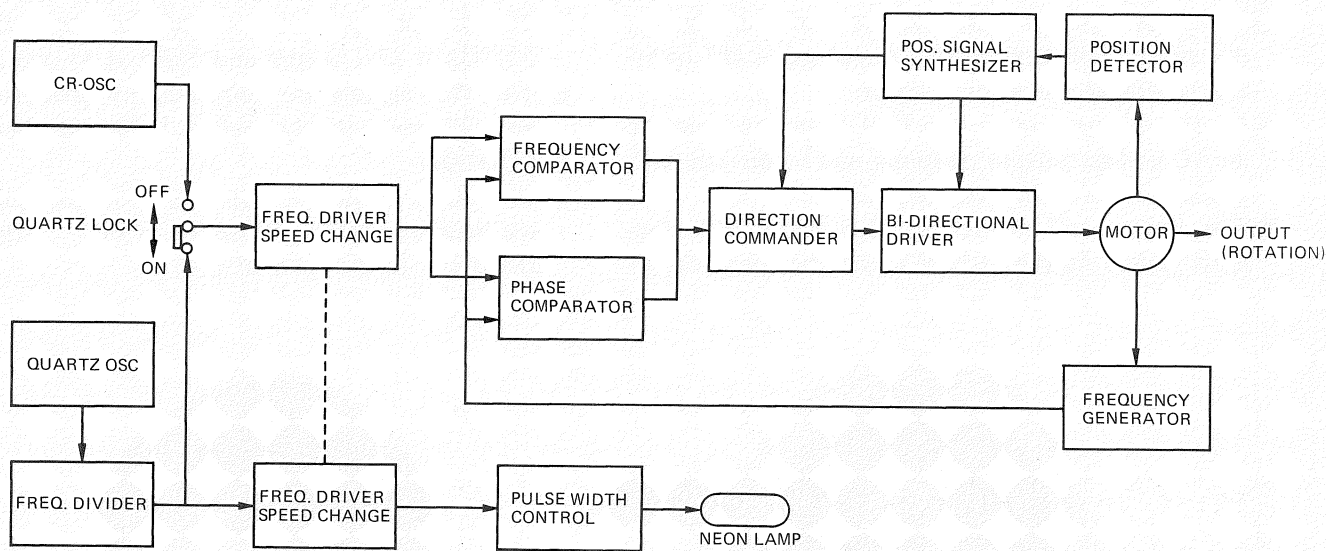

Fig. 6 Block diagram of PL-570 control circuit

With QUARTZ LOCK ON, the motor speed is locked in to the rated speed of either 33-1/3 or 45 rpm. When it is OFF, manual adjustment is possible.

The motor is a DC brushless type without a commutator. Instead, it has three position detectors composed of Hall elements, which will be described later.

Drive currents are supplied from the bi-directional driver.

The position signal synthesizer produces step waves by synthesizing the output signals generated by the Hall elements, and gives an order to the bi-directional driver nominating to which coils the drive currents must be supplied.

Simultaneously, it gives signals to the direction commander which determines in which direction rotation torque must be generated.

On the other hand, the frequency of the signal generated by the quartz or CR oscillator is divided and the signal is also supplied to the frequency and phase comparators.

When the motor is rotating at precisely the rated speed, these signals (reference and motor output) have the same frequency and the phase difference is zero.

The comparators detect errors in both frequency and phase.

If an error arises, namely a lag in speed or wow and flutter, the comparators immediately detect the error and send a correcting signal to the bi-direction-

al driver via the direction commander.

Since this operation is performed instantaneously, rotational speed is always kept exact and smooth. When the QUARTZ LOCK is turned OFF, the oscillation frequency of the CR oscillator can be manually varied by  $\pm 6\%$ .

In this case also, the PLL operation is performed in exactly the same manner as QUARTZ LOCK ON, and stable rotation is assured.

For reference, strobo grooves are engraved in the outer rim of the platter, and a neon lamp illuminates the grooves to facilitate checking of the rotation speed.

Since the neon lamp is driven by a frequency-divided signal from the quartz-oscillator, the illuminated strobo grooves remain stationary as long as the platter is rotating at the rated speed. If the strobo lamp were to be lit by commercial power, the strobo grooves would move back and forth as the frequency fluctuates.

In addition, use of one-stripe strobo grooves enables both speed checking and controlling to be carried out. Conventional strobo markings used for fine speed control on other turntables are normally illuminated by commercial power, thus requiring four strips to be embossed on the platter rim corresponding to the power supply frequency and rotation at both speeds.



### 3. Circuit Operation

#### 3.1 Operation of Motor and Drive Circuit

##### 1) Motor structure

- The motor is an outer-rotor, 6-pole, 9-slot, brushless type as shown in Fig. 7a.
- The coils form a 3-phase star, as shown in Fig. 7b, on which Hall elements are mounted at  $40^\circ$  intervals to detect the rotor position.
- As the motor rotates, the Hall elements generate an AC voltage output proportional to the strength and direction of the magnetic field.
- The bottom of the rotor magnet has 200 magnetic poles. As they rotate above the speed detec-

tion plate, two AC voltages are generated which serve as the speed detection signals.

- The speed detection plate has two circuit patterns, and the output of the inner pattern is  $90^\circ$  out-of-phase from that of the outer pattern.
- The frequency of the speed detection signal is 55.5Hz at 33-1/3 rpm and 75Hz at 45 rpm.
- The two signals are amplified by transistors Q1 and Q2, respectively, before being supplied to IC PD-1001.
- The inner surface of the rotor magnet possesses six magnetic poles. As shown in Fig. , these are tilted  $10^\circ$  to the vertical axis.

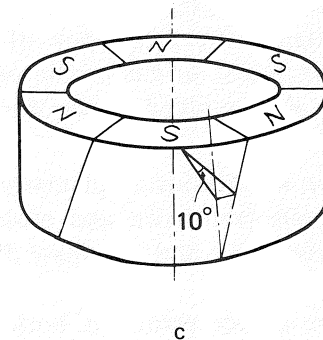
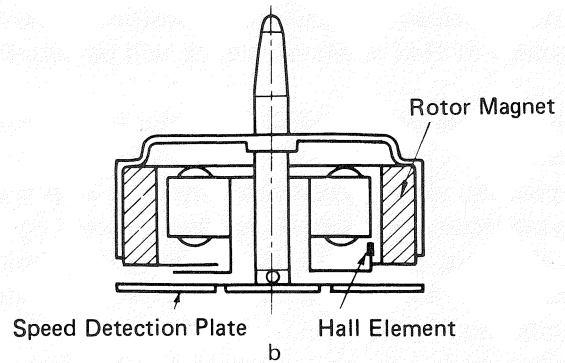
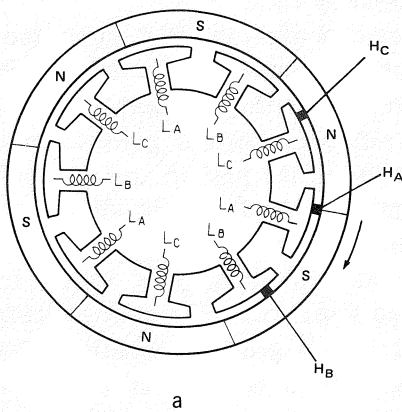
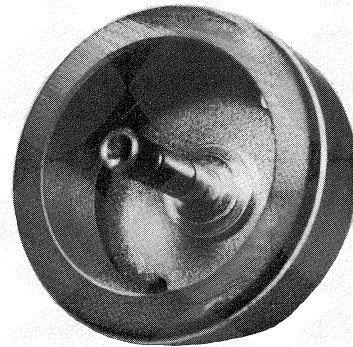
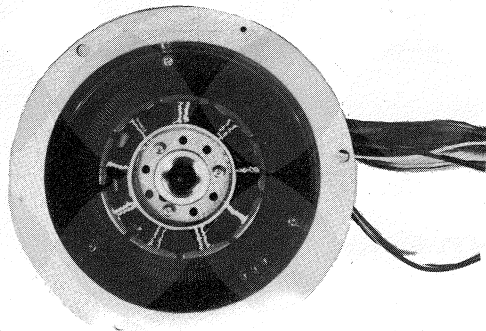

Fig. 7 Motor structure

2) Principle of motor rotation—drive current and excitation

- a) As shown in Fig. 8, step signals are supplied to the coils. (Generation of step-wave signals will be described later.)
- b) Assuming that the motor is stopped in the position shown in Fig. 7a, then.
- c) When the power switch is turned ON, drive current is supplied to LA and LB for period a. As LA is energized it becomes an S pole and LB becomes an N pole. The motor then starts to rotate clockwise (see Fig. 9a).

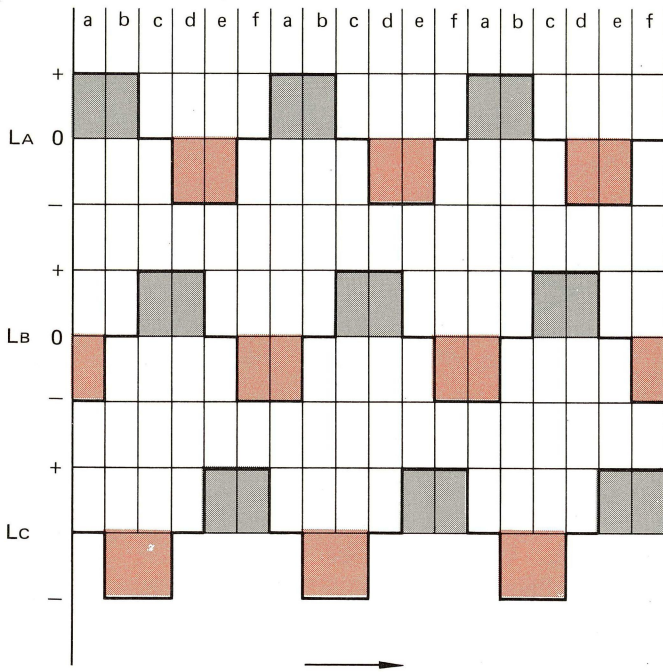

Fig. 8 Drive current waveform

- d) At the next period, b, the drive current is supplied to coils LA and LC. LA becomes the S pole and LC becomes the N pole, and the motor continues to rotate (see Fig. 9b).
- e) The excitation current is switched sequentially to drive the coils which excite the mated cores in a continuous S – N and N – S pole sequence to maintain motor rotation (see Figs. 9a to 9f).
- f) The complete operation sequence covers steps a to f, during which time the motor makes 1/3 of a revolution. The sequence is repeated three times for one complete revolution.

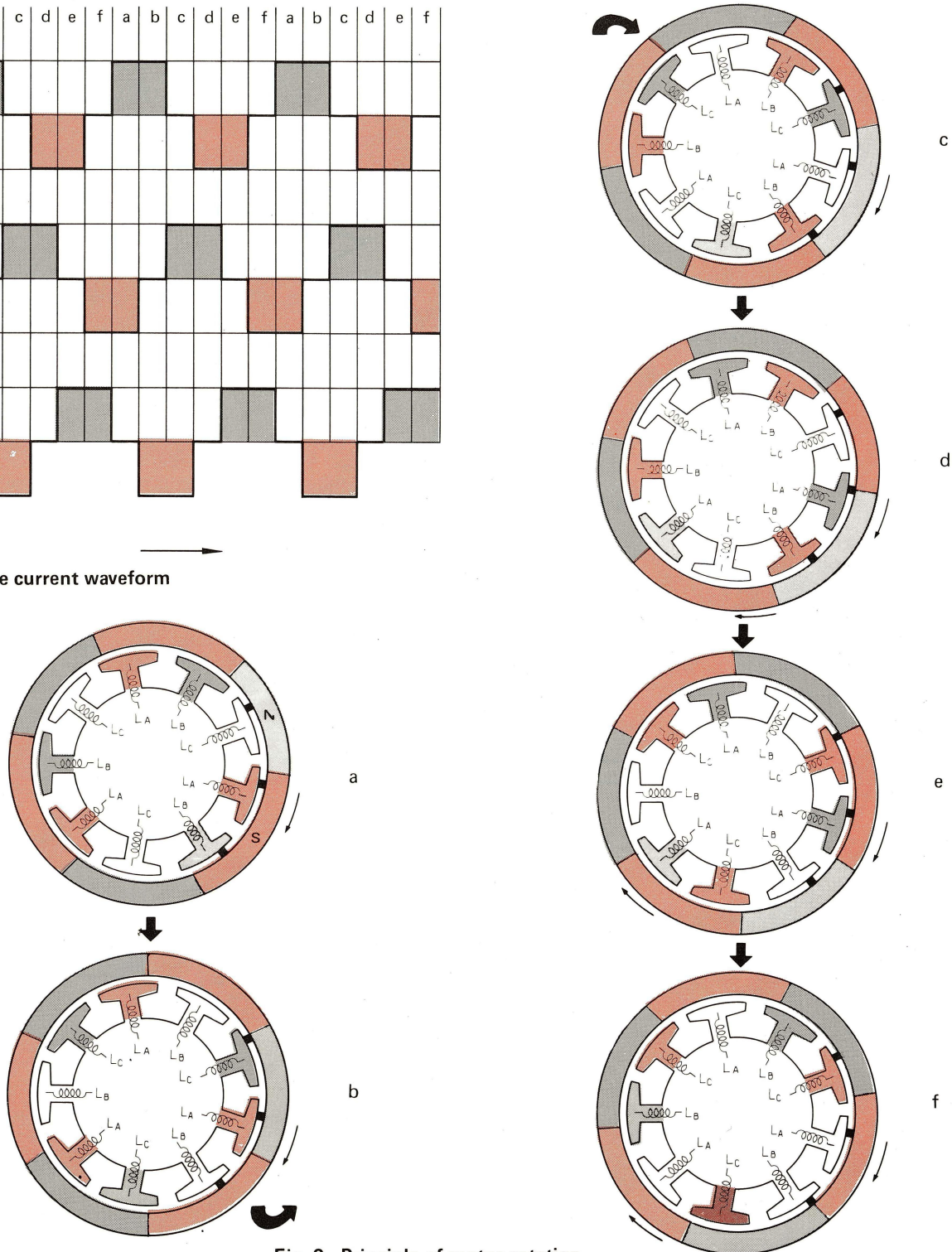

Fig. 9 Principle of motor rotation

### 3) Position detector—Hall element and shaping of drive current

Now, let's see how the motor actually rotates. In order to make the motor rotate, drive currents as shown in Fig. 8 are required. These are generated by the Hall elements and the position signal synthesizer. The Hall elements function as shown in Fig. 10. When voltage is supplied to a Hall element (a semiconductor with a large carrier mobility), the current through electrodes c and d produces a voltage across electrodes a and b which corresponds to the polarity of the external magnetic flux. If the direction of the magnetic flux is reversed, the polarity of the

voltage across electrodes a and b is also reversed. Returning to Fig. 7 again, if we assume that the motor is at a standstill in the position shown, then Hall element HA will face the neutral zone between the N and S poles, HB will face the S pole and HC the N pole. When the power is turned on, the Hall elements will produce voltages across their terminals (terminals 1, 3, 5, 7, 8 and 10 of the PWX-006 as shown in Fig. 11). These voltages are then composed into drive current waveform signals by the position signal synthesizer, then amplified and supplied to the individual coils (see Fig. 11).

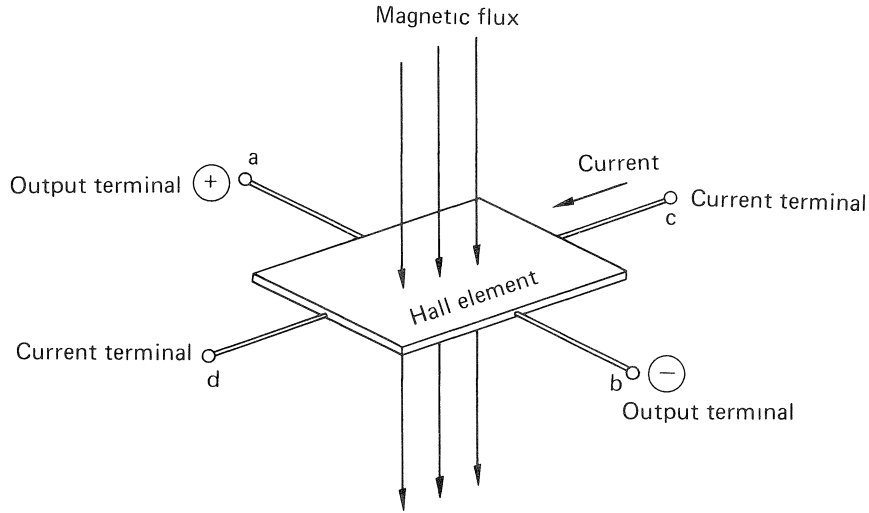

Fig. 10 Hall element and its operation

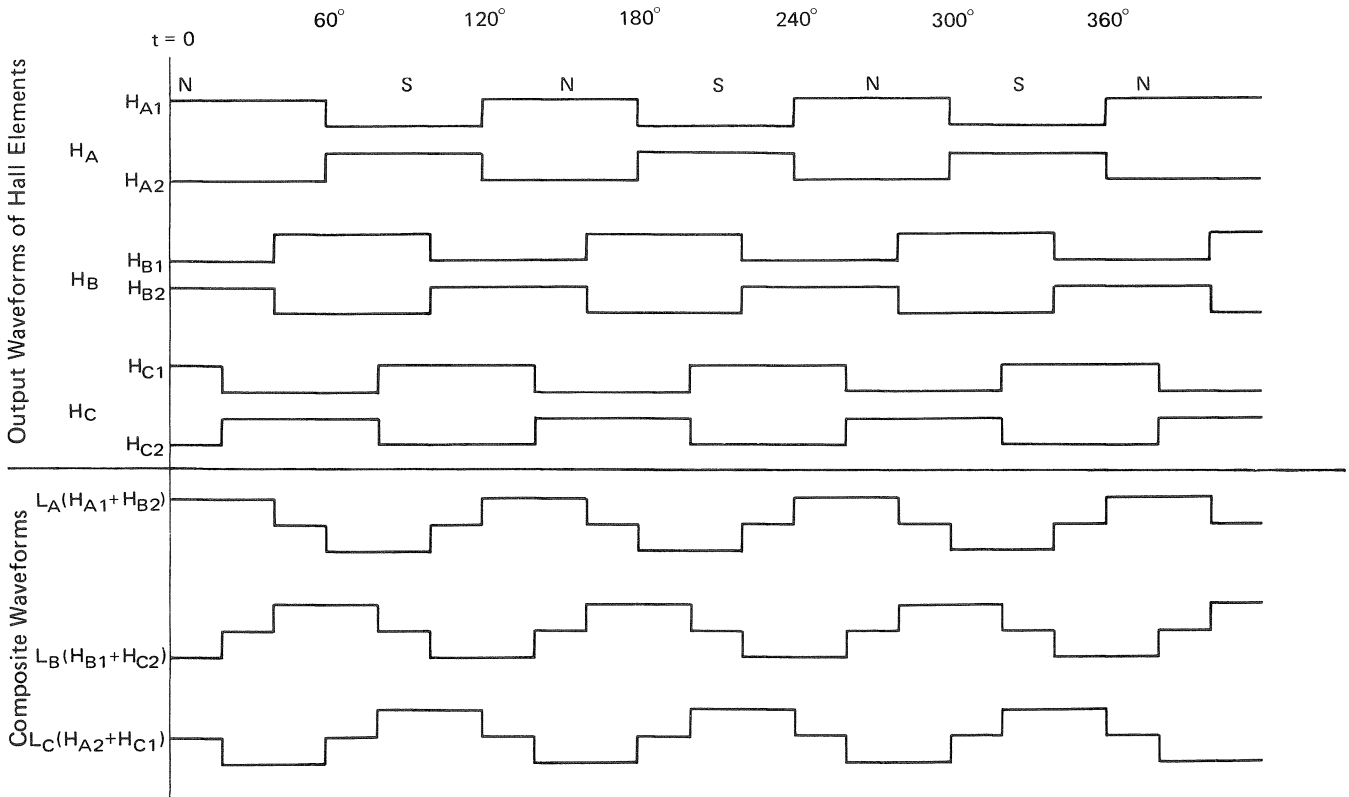

Fig. 11 Hall element outputs and shaping of drive current

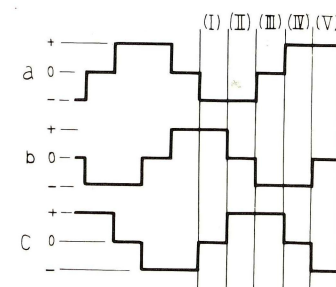
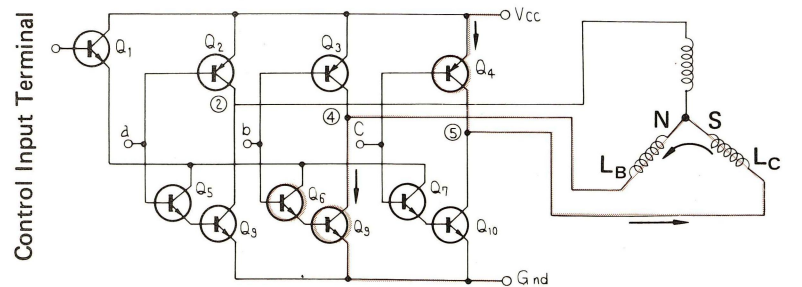
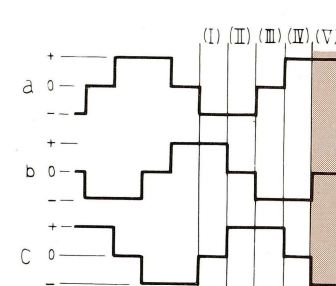
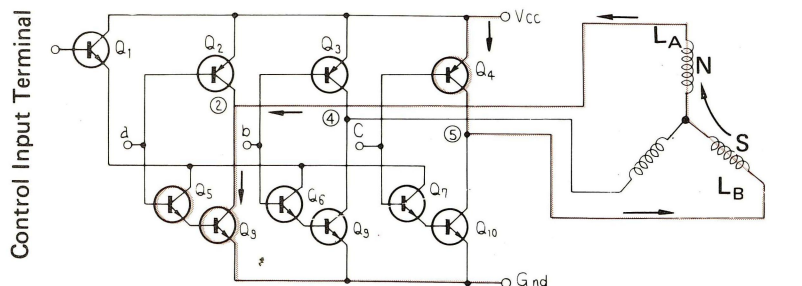
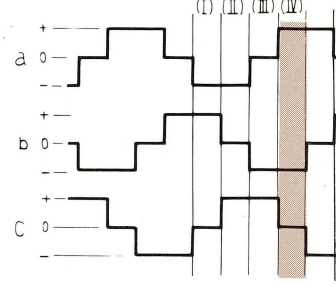
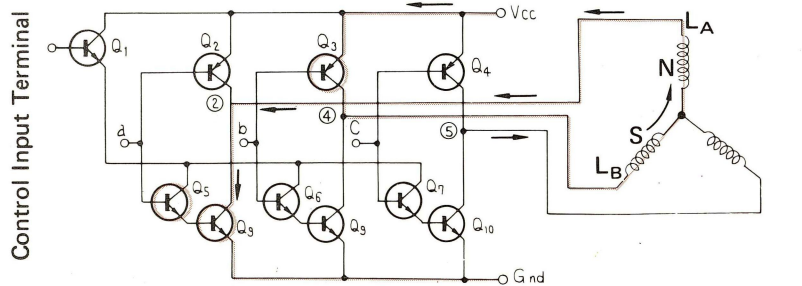
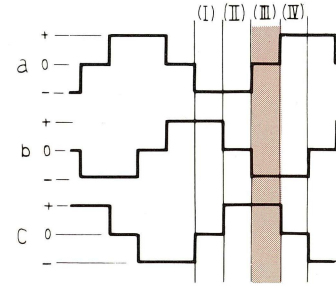
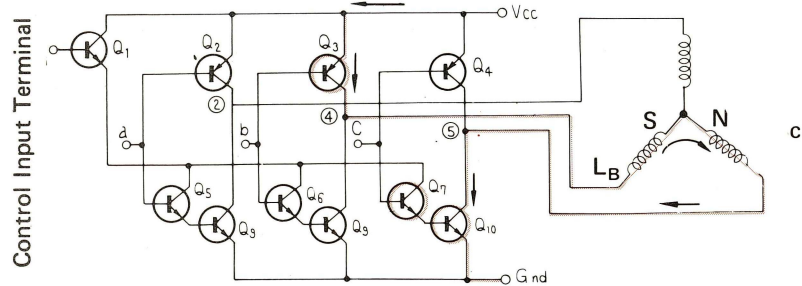
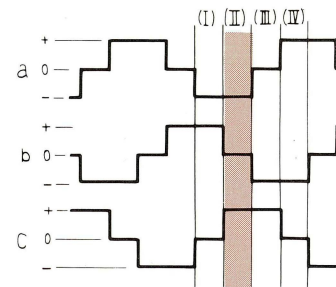
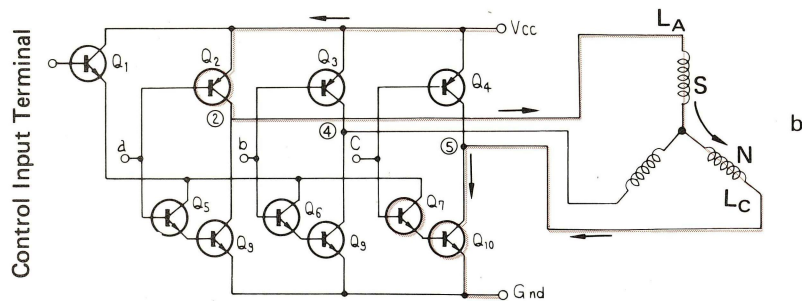
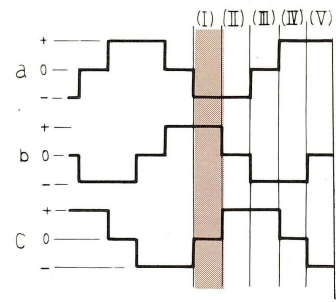
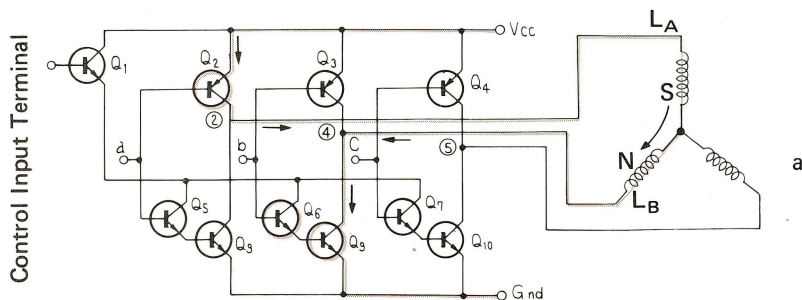

Fig. 12 Drive current switching

Fig. 13 Drive currents

#### 4) Motor drive circuit

The motor drive circuit is contained in IC PA2001, and the circuit configuration is as shown in Fig. 12. In order to switch Q2 through Q7, signals from the position signal synthesizer are supplied to terminals a, b and c as shown in Fig. 13. The bias voltages are established so that the voltages at points 2, 4 and 5 are equal and no drive current flows to the coils when no input signal is supplied. The drive circuit operates as follows (see Figs. 12 and 13):

#### 5) Drive Circuit

- a) Switching signals obtained from the three Hall elements and having been processed in the Position Signal Synthesizer Circuit, applied to terminals a, b and c in Fig. 9, in order to switch Q2 ~ Q7.
- b) These signals are step waves as shown in Fig. 10, with relative phase differences of  $120^\circ$  between them.
- c) Because of the low potential at pin (a), Q2 is ON. Pin (b) is at high potential, so Q6 and Q9 are ON. Pin (c) is at neutral potential – a neutral bias is applied which keeps Q4, Q7 and Q10 OFF.
- d) A current caused by voltage  $V_{CC}$  flows through Q2 – (2) – coil  $L_A$  – coil  $L_B$  – (4) – Q9, causing an N pole to appear at  $L_B$  and an S pole at  $L_A$ .
- e) This magnetism causes the rotor to start rotating. After 20 degrees of rotation, the signal levels at terminals a, b and c will become as shown in Fig. 13-b II, and the current path of the drive current is changed. After another 20 degrees of rotation, the signals become as in Fig. 13-c III, and the drive current path is changed again. This process continues, with current path changes every 20 degrees and signal levels as in Figs. 13-d IV, 13-e V, and 13-f VI, whereupon the cycle returns to 13-a and repeats.
- f) Also, a control signal from the Forward/Reverse Command Block is applied to the control input terminal, and this controls the current flow through the motor windings.

### 3.2 Control block diagram

Referring to Fig. 14, the control block is composed of a reference signal oscillator (QUARTZ OSC., CR OSC and frequency divider), a speed detection cir-

cuit (frequency generator), comparators (frequency and phase comparators) and a direction command circuit (direction commander).

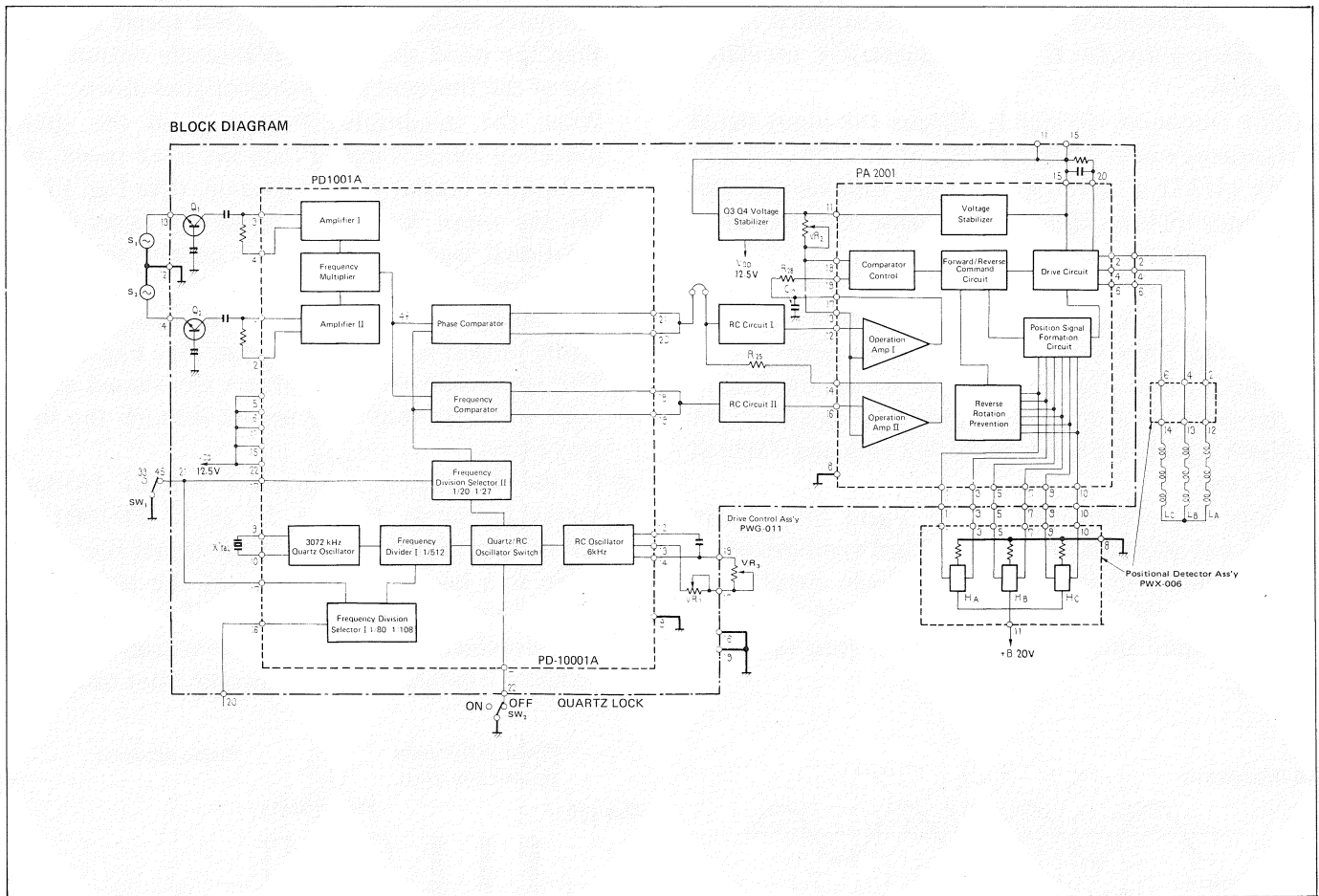
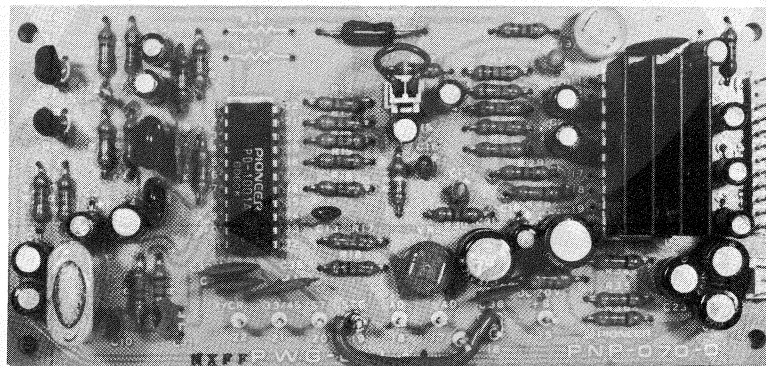
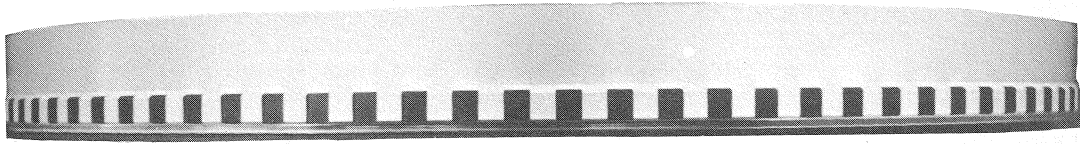
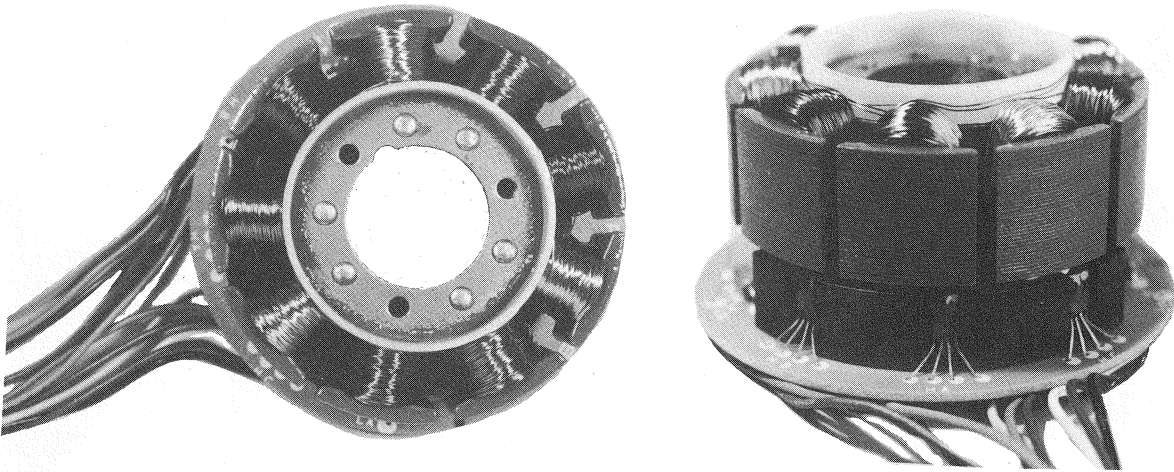

Fig. 14 Block diagram of control block





Platter



States and hall elements

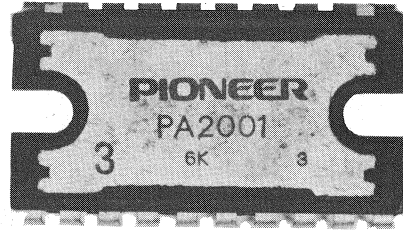
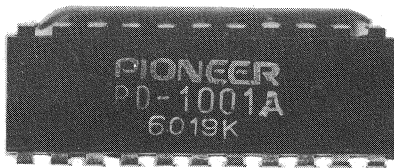

IC's (PA-1001A and PA-2001)

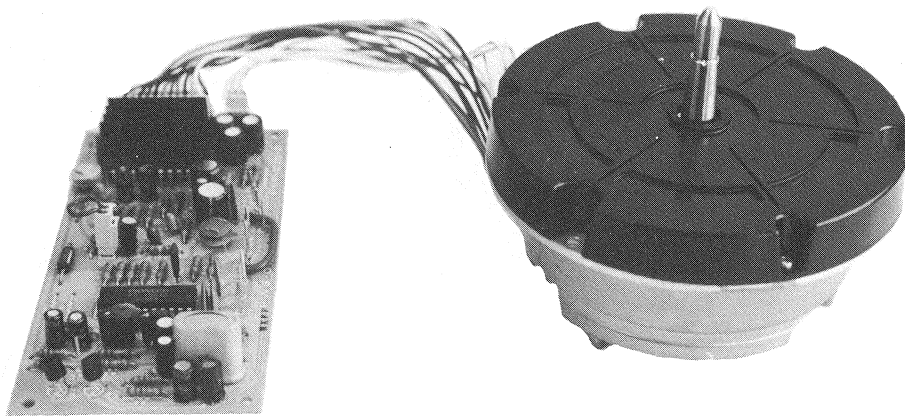

Drive control assembly and motor

**1) Reference signal, speed-detecting signal generators and comparators (PD1001A)**

- a) When power is supplied, the quartz oscillator starts to oscillate at 3,072kHz.
- b) This signal is frequency-divided to 6kHz (1/512), and the frequency-divided signal is supplied to the frequency-divider II via the Quartz/CR oscillator switch.
- c) The frequency-divider II divides the input signal frequency into 300Hz (1/20) at 45 rpm and 222 Hz (1/27) at 33-1/3 rpm, and supplies the frequency-divided signal to the phase and frequency comparators.
- d) The speed-detecting signals generated by S1 and S2 (see Fig. 15a) are amplified by transistors Q1 and Q2 then waveform-shaped by amp. I and Amp. II (see Fig. 15b) before being supplied to the frequency doubler circuit. The frequency of these signals is 55.5Hz at 33-1/3 rpm and 75Hz at 45 rpm.
- e) Since the outputs from Amp. 1 and Amp. II are 90° out-of-phase, these signals are synthesized to a frequency-doubled signal in a logic circuit, and further multiplied to 4f signals to produce 300Hz at 45 rpm and 222Hz at 33-1/3 rpm (see Fig. 15b).

- f) This frequency-multiplied signal is supplied to both the frequency and phase comparators, and compared with the reference signal. When the quadrupled frequency of the speed detecting signal is lower than the frequency of the reference signal (i.e. the rotation speed is lower than the rated speed), the composite output voltage of the frequency comparator goes down. When the quadrupled frequency of the speed detecting signal is higher than the rated speed, the composite output voltage goes up. (See Fig. 17) On the other hand, if a phase lag arises (i.e. a rotational lag), the composite output voltage of the phase comparator goes up. Conversely, if a rotational advance arises, the composite output voltage goes down. (See Fig. 16) The composite output voltages mentioned above refer to those that have passed through the low-pass filters.
- g) If the frequency comparator output (voltage across terminals 18 and 19 of IC PD1001) is lower than that of the reference signal (i.e. when there is a lag in the rotation of the rotor), the synthesizer output is set at HIGH (see Fig. 17). The waveform of the composite voltages in Figs. 16 and 17 indicate the CR lowpass filter output.

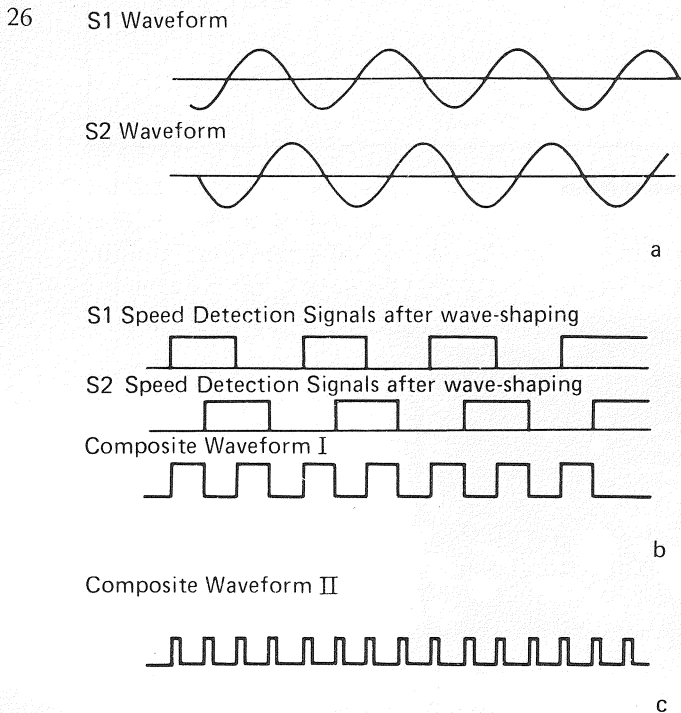

Fig. 15 Waveforming of speed-detecting signal

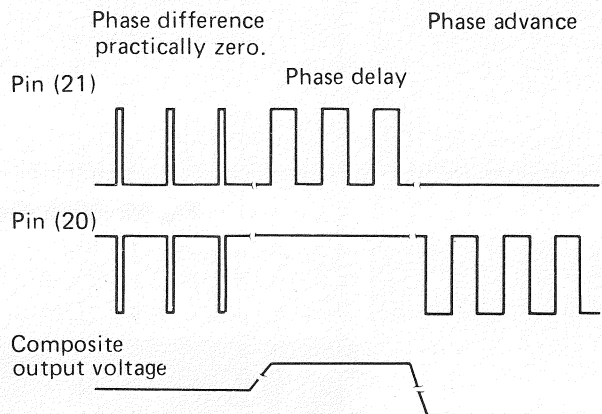

Fig. 16 Output of phase comparator

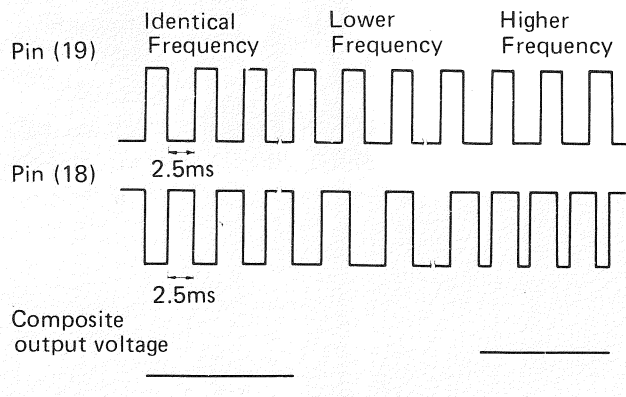

Fig. 17 Output of frequency comparator



**Note:** The composite output voltages in the above figures refer to those that have passed through the low-pass filters.

h) A nonstable multivibrator in the CR OSC circuit generates a 6kHz signal. With the quartz lock switch OFF, the reference signal is obtained from the CR oscillator. Like the reference signal with the quartz lock ON, this signal is frequency-divid-

ed in the frequency-driver II and supplied to the phase and frequency comparators.

- i) With the quartz lock OFF, the CR OSC output frequency can be varied by  $\pm 6\%$  by turning the speed adjustment control knob.
- j) This adjustment of the CR oscillator results in an equivalent change in the motor speed.

2) Active filter (Low-pass filter)

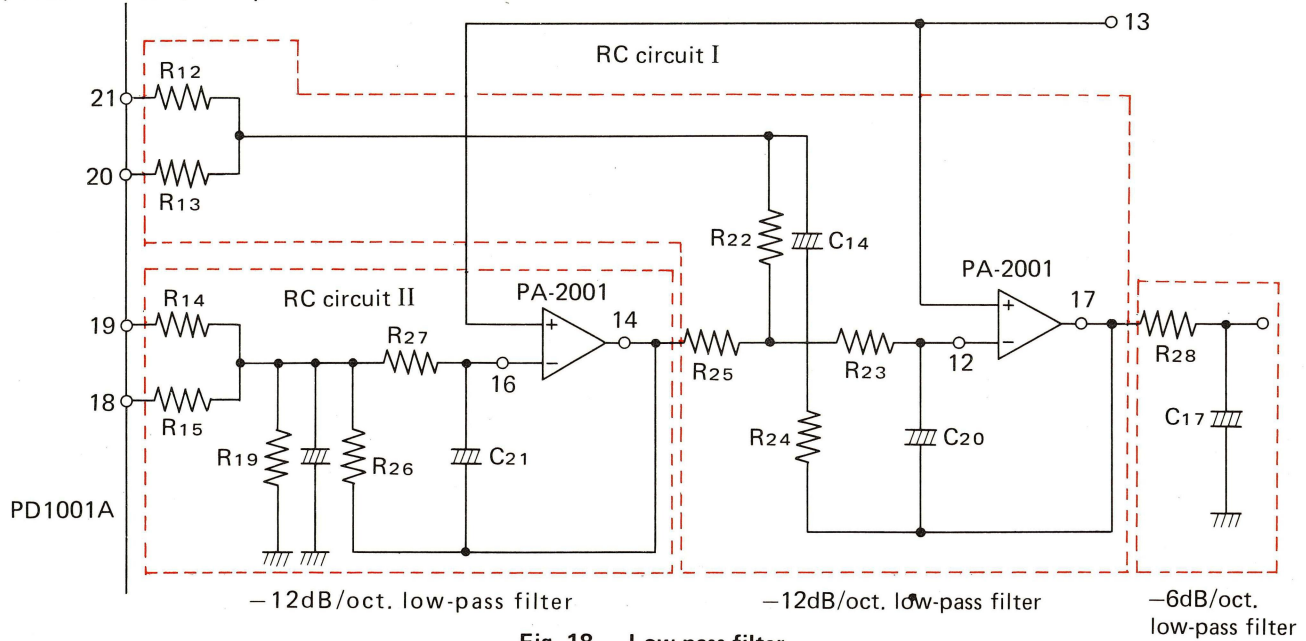

Fig. 18 Low-pass filter

Since the outputs from the phase and frequency comparators are not yet rectified to DC, they cannot be used directly as speed control signals. In order to control the motor drive circuit, these signals must first be converted to DC voltage and combined into one signal. For this purpose, RC circuits are provided as lowpass filters, and those shown in Fig. 18 are taken from actual circuits.

As the outputs from the comparators contain the components of the reference signal and the harmonics of the speed-detecting signal, it is necessary to provide a large amount of attenuation at the higher frequencies without causing major phase changes at the lower frequencies. Thus, sharp attenuation characteristics are obtained from the active filters.

The phase comparator output is filtered by a  $-12\text{dB/Oct}$  active filter composed of RC circuit I and operational amplifier I in IC PD2001, as well as a  $-6\text{dB/oct}$  low-pass filter composed of R28 and

C17. Altogether, the phase comparator output is attenuated by  $-18\text{dB/oct}$ .

The frequency comparator output is filtered by a  $-12\text{dB/oct}$  active filter composed of RC circuit II and operational amplifier II in IC PD2001, which is combined with the output of operational amplifier I via resistor R25. Altogether, the frequency comparator output is attenuated by  $-30\text{dB/oct}$  ( $-12/-12/-6$ ).

The cut-off frequency of these filters is set at 12Hz, and these active filters also function as inversion amplifiers.

The output from the active filter is  $180^\circ$  out-of-phase with that of the phase comparator and in-phase with that of the frequency comparator. Thus, the voltage at pin 18 of IC PA2001 increases when the motor speed is faster than the rated speed, and decreases as the speed lowers.

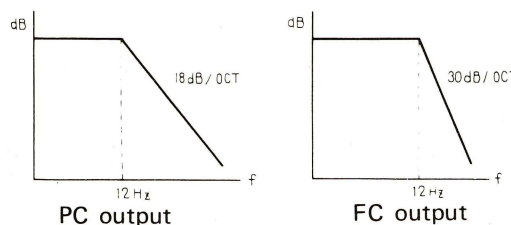

Fig. 19 Filter characteristics

### 3) Comparator control and direction command circuit

The comparator control has two input terminals. One receives a 5V reference voltage from the voltage-regulated power supply. The other receives the output voltage from the active filter. The output is higher than the reference voltage when the rotor speed exceeds the rated speed, and lower when there is a lag in speed.

Whenever a lag is detected in the motor speed, the control circuit commands the drive circuit, via the direction command circuit, to generate greater torque in order to increase rotor speed. This circuit also commands the drive circuit to generate more torque when the motor speed is faster as well. In this case, the direction command circuit orders the position signal synthesizer to generate reverse torque.

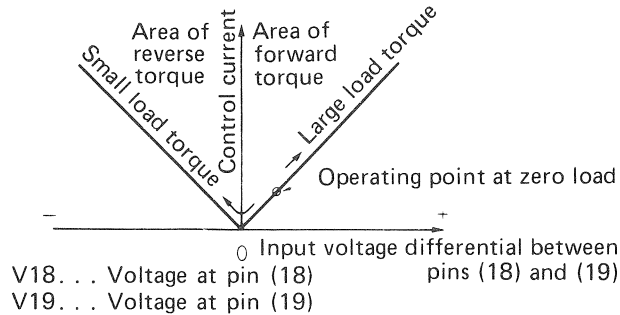

Fig. 20 Comparator input/output voltages

When the position signal synthesizing circuit receives a reverse torque command from the direction command circuit, it changes the composition of the output signals from those which the Hall elements sensed, and the motor drive circuit receives the switching signals in a different sequence. For ex-

ample, when the rotor speed is slower than the rated speed, the switching sequence is LA – LB – LC. When it is faster, the sequence is changed to LA – LC – LB. As a result, reverse torque is generated (see Fig. 21 and 22).

28

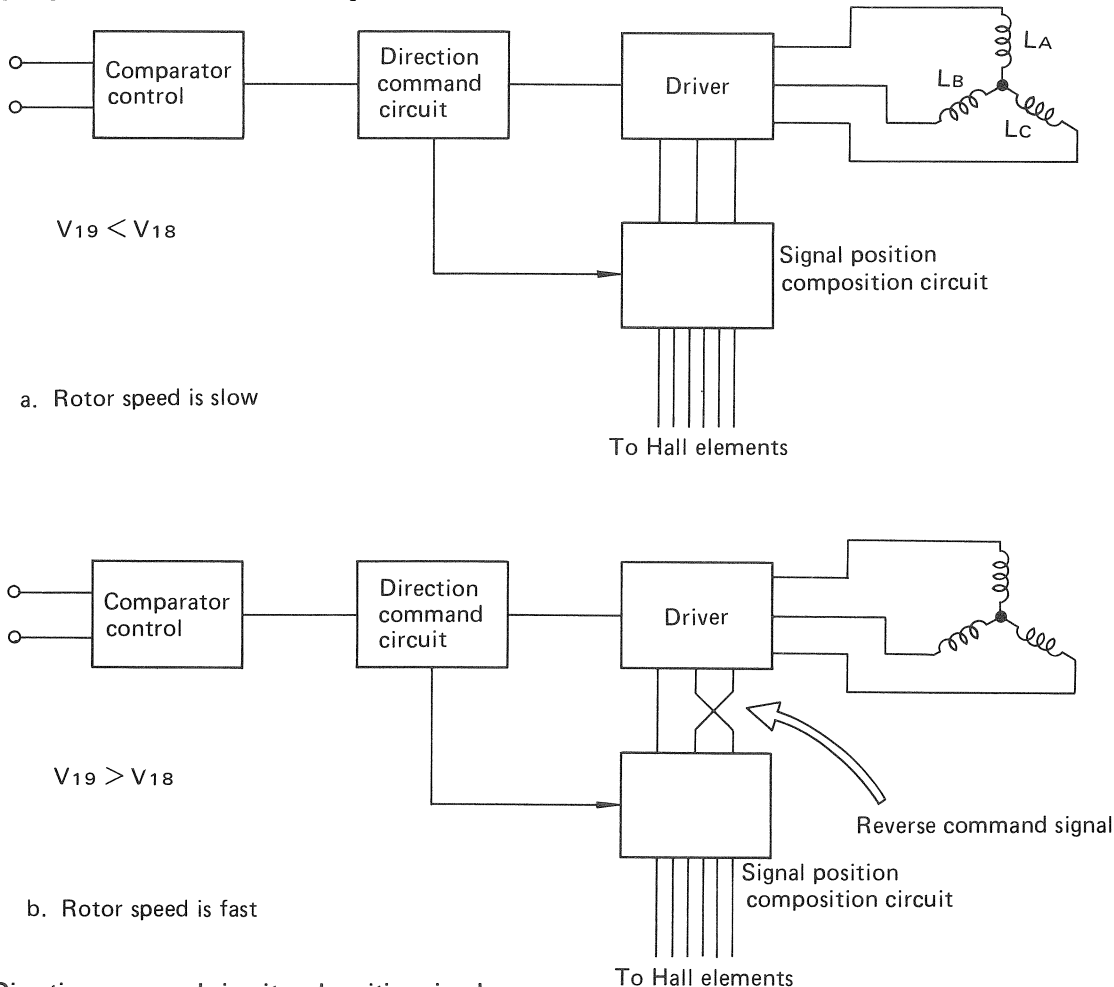

Fig. 21 Direction command circuit and position signal composition

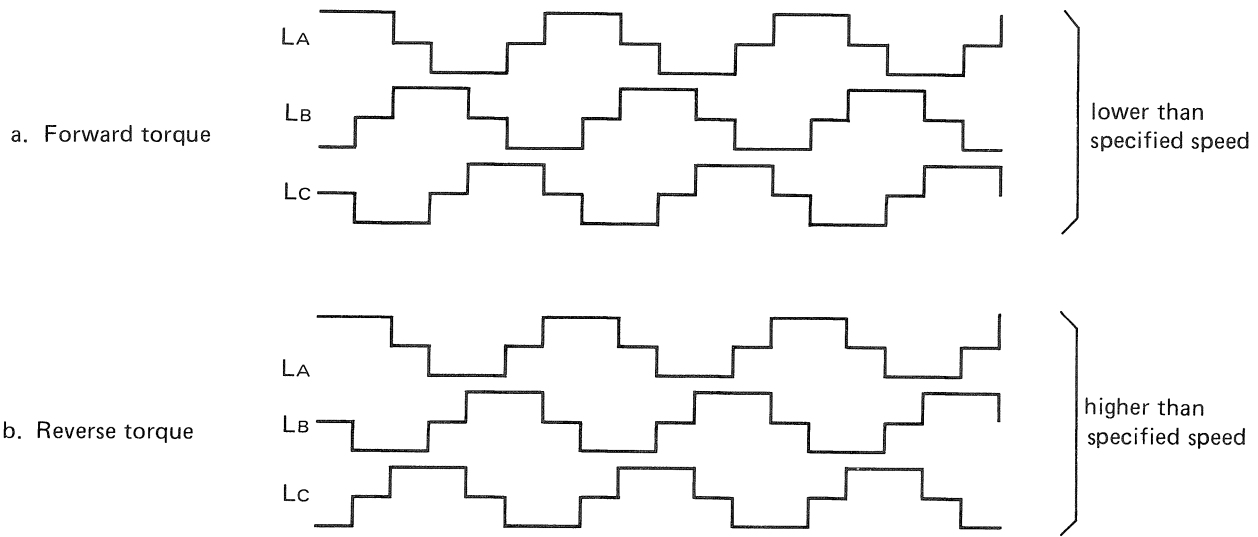

Fig. 22 Forward/reverse torque and switching signals

#### 4) Reverse rotation prevention circuit

Whenever the motor speed is slower than the rated speed, forward torque is generated to restore it to normal. Likewise, if the platter is manually forced to turn in the reverse direction, a greater torque is generated. And after releasing the platter, the rotation eventually reaches its rated speed in the proper direction. If, however, the rotational speed in the reverse direction is in excess of 33-1/3 or 45 rpm, the bi-directional driver may read this as simply excessive speed (overrun) and command the motor drive circuit to apply reverse torque. This will result in further acceleration in the reverse direction which is known as 'reverse run-away.' To prevent this, a reverse prevention circuit has been included.

The reverse rotation prevention circuit is composed of two flipflops (FF) and an AND gate in IC PD 2001. The input for this circuit is derived from the Hall element position direction signals processed in the positional signal synthesizing circuit (see Fig. 21). The output from this circuit is supplied to the direction commander. At forward rotation, input pulses are supplied in the B – A – C sequence, and the direction commander outputs a forward torque signal (the rotor is forced to rotate forward when the output from the direction commander is zero).

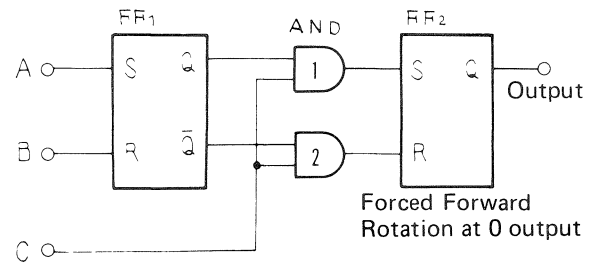
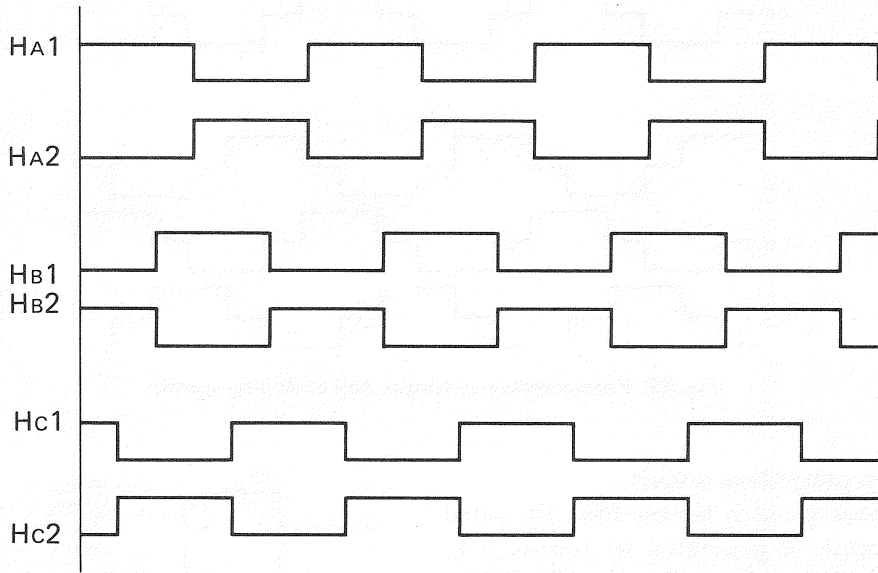

Fig. 23 Reverse Rotation Prevention Circuit

	FF <sub>1</sub>				C	AND		FF <sub>2</sub>
	S	R	Q	$\bar{Q}$		1out	2out	
Forward rotation	B	0	1	0	1	0	0	
	↓							
	A	1	0	1	0	0	0	
Reverse rotation	↓							
	C	0	0	1	0	1	0	1
	↓							
	A	1	0	1	0	0	0	
Reverse rotation	↓							
	B	0	1	0	1	0	0	
	↓							
C	0	0	0	1	1	0	1	0

OUTPUT WAVEFORMS OF HALL ELEMENTS



FORWARD ROTATION

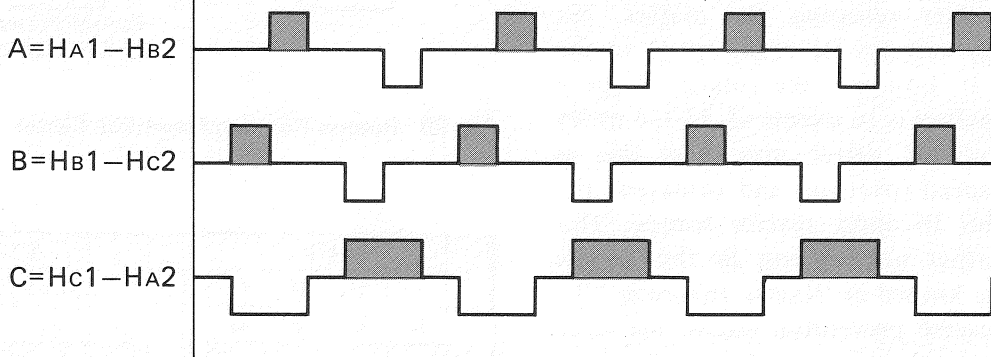

REVERSE ROTATION

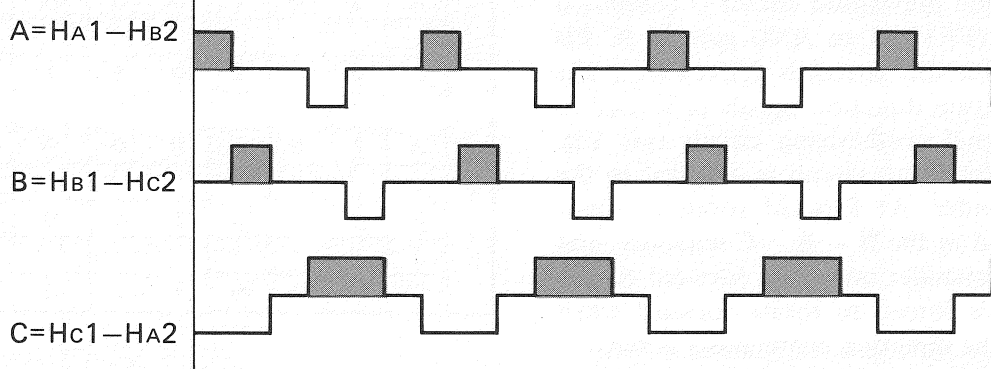

COMPOSITE SIGNALS FOR REVERSE ROTATION PREVENTION

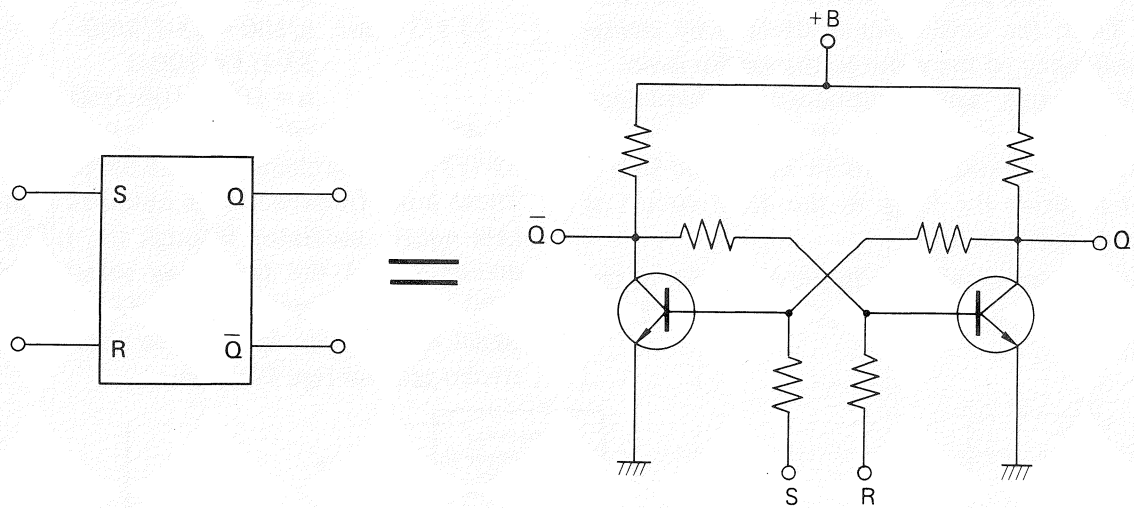

Fig. 22 Flipflop circuit

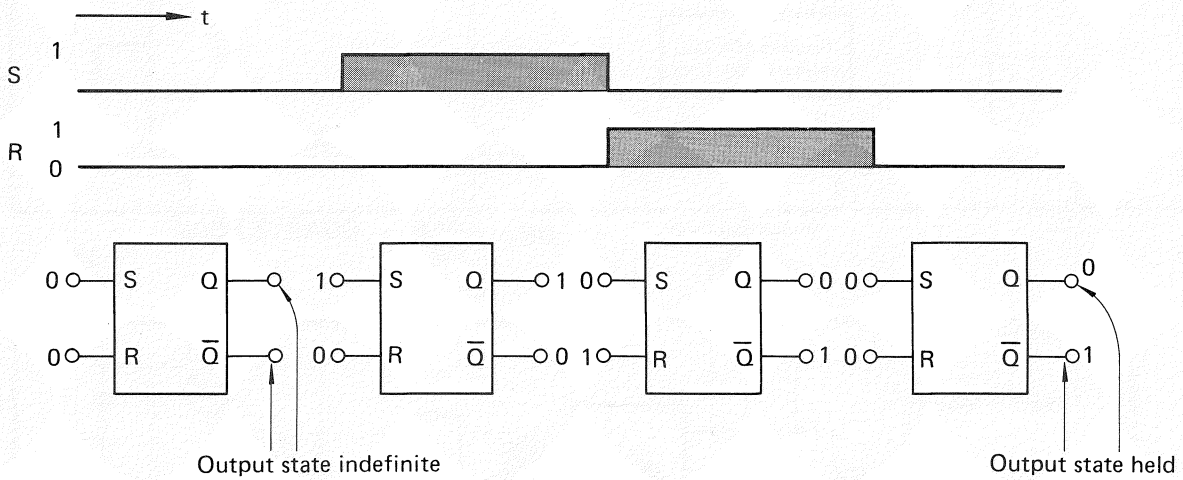
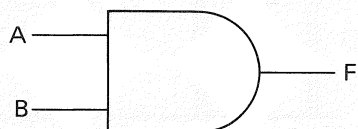

Fig. 23 Flipflop circuit operation

AND gate symbol



A	B	$F = A \cdot B$
0	0	0
1	0	0
0	1	0
1	1	1

Truth table for AND gate

### 5) Strobe-lighting pulse circuit

As mentioned, the platter has only one set of strobe grooves. Thus, the switchover is effected by changing the frequency of the pulse to the strobo lamp.

The strobe-lighting signal is obtained by frequency-dividing the pulse signal from the quartz oscillator in PD1001A. It is amplified to an amplitude that is sufficient to drive the lamp in the drive circuit of the power supply assembly.

From the 100 strobo grooves in the outer rim of the platter, the following pulse-cycles-per-second are obtained:

$$45 \text{ rpm: } n/100 = 45/60 \text{ (n: pulse/sec.)}$$

$$n = 100 \times 45/60 = 75$$

$$33\text{-}1/3 \text{ rpm: } n/100 = 33\text{-}1/3/60$$

$$33\text{-}1/3 = 100/3$$

$$n = 100 \times 100/3/60 = 55.55$$

At 45 rpm, the pulse frequency is set at 75Hz and at 33-1/3 rpm it is changed to 55.55Hz.

These pulse frequencies are obtained from the 3,072 kHz quartz oscillator through the 1/512 frequency divider 1 and the frequency selector which select 1/80 at 45 rpm and 1/108 at 33-1/3 rpm. The pulse signal is waveform in shape to clearly illuminate the strobo grooves (see Fig. 28).

32

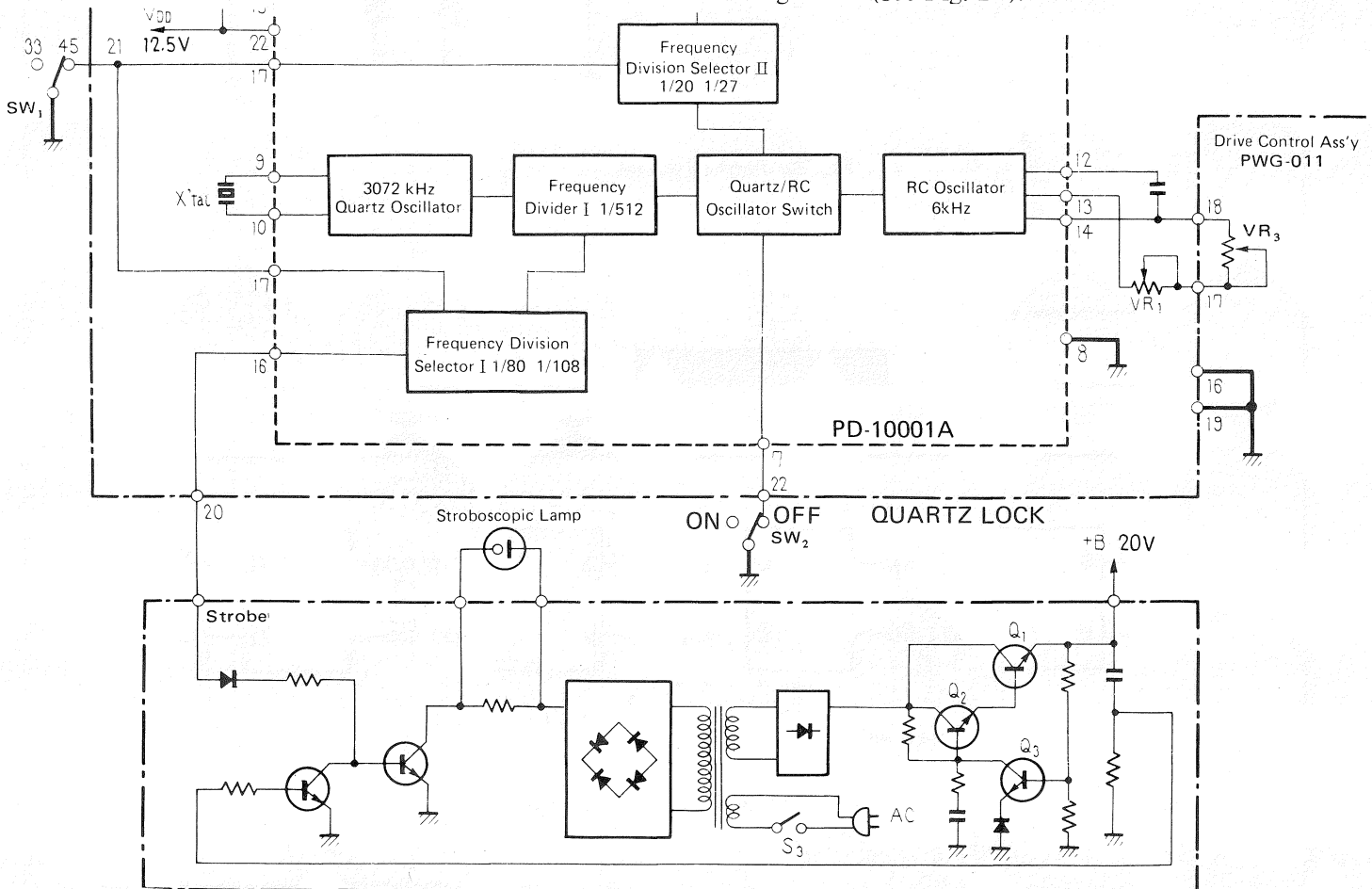

Fig. 27 Strobe-lighting signal circuit

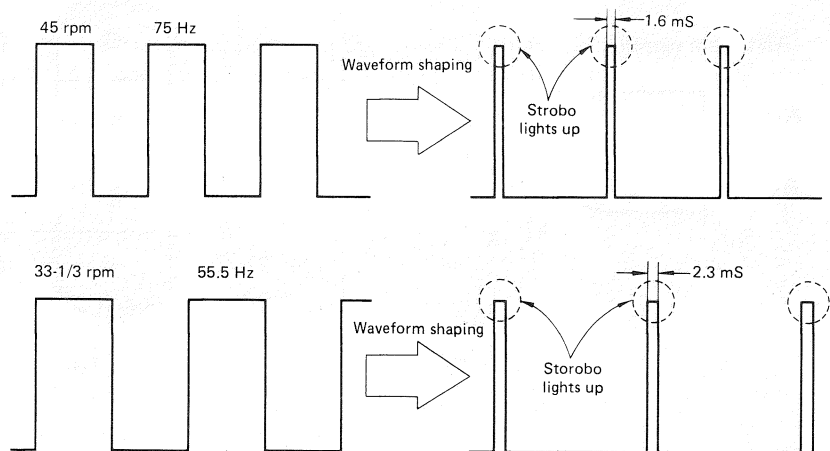

Fig. 28 Strobe-lighting signal

## 4. Troubleshooting Steps

### 4.1 Possible causes of trouble

Theoretically, the number of possible causes of trouble in a direct-drive turntable is unlimited, however, in actual fact they can be broken down into the following main causes:

- 1) No rotation
- 2) Reverse run-away
- 3) Repeated forward-reverse rotation
- 4) Unstable speed near the rated speed

### Servicing Precautions and Aids

### 4.2 Circuit waveforms

The causes of trouble occurring in circuit waveforms can be easily located by checking the voltage distribution and signal waveforms in the drive and control block and comparing them with those listed in the service manual. The normal circuit voltages and signal waveforms are shown in Fig. 29 and 30.

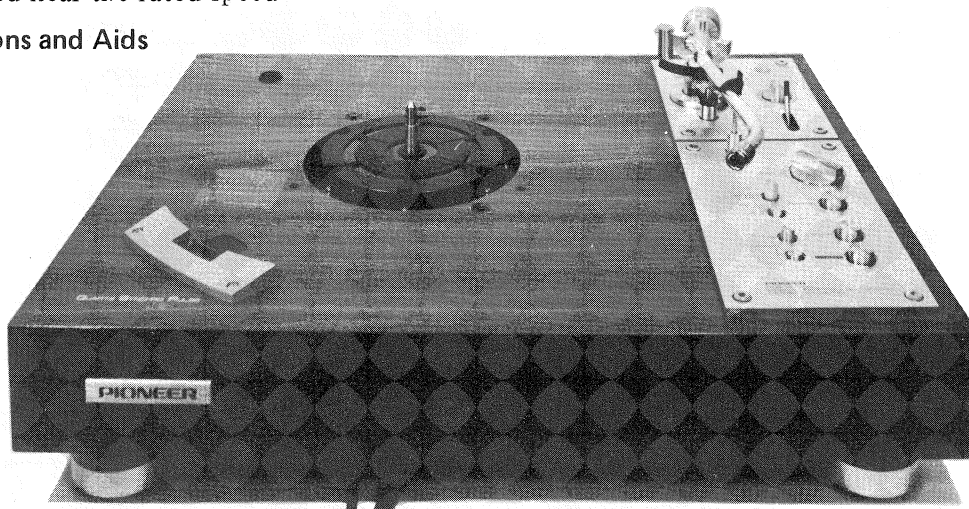

1. Never turn the power on with the platter removed.

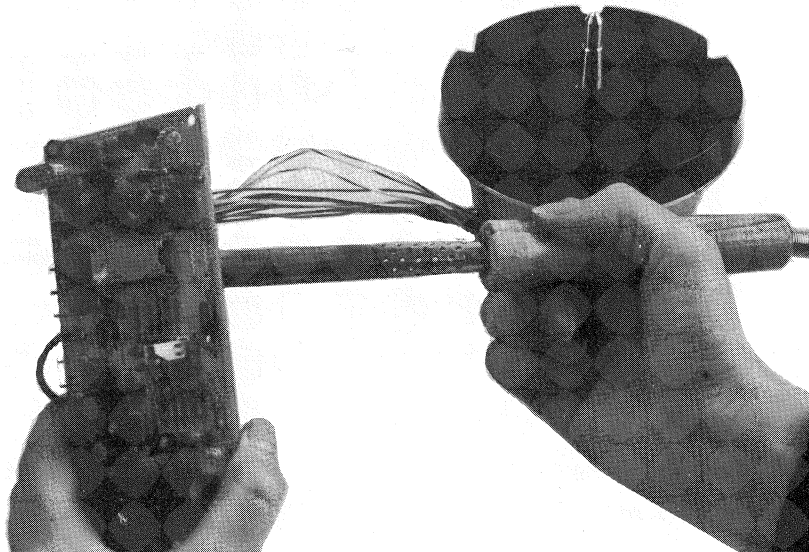

2. Never replace IC without the aluminum cover.
3. Never leave motor disassembled in dusty place.

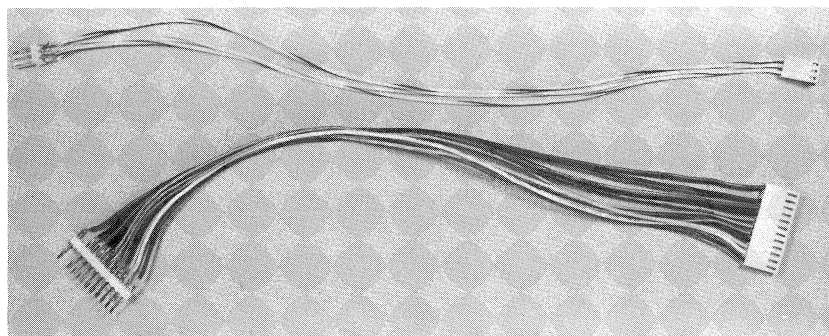

4. Convenient devices for checking and repairing.

1) Waveforms

DRIVE CONTROL ASS'y PWG-011

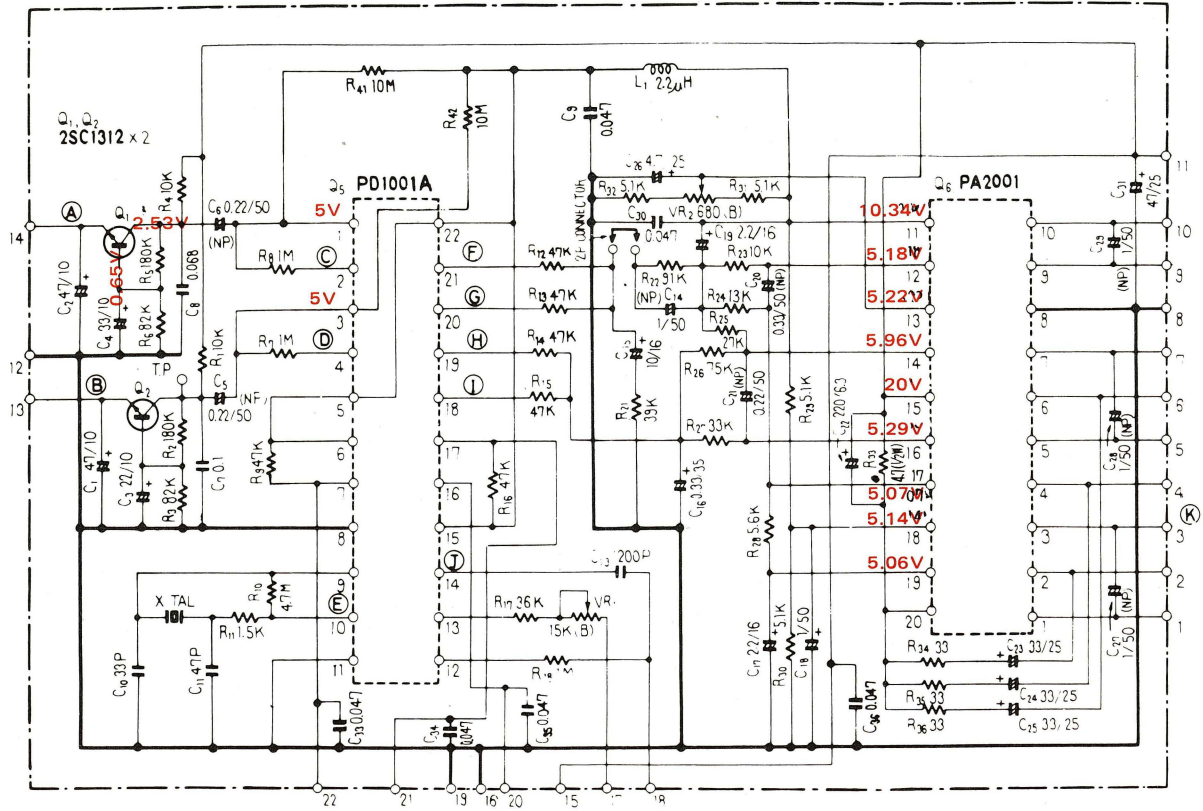

34

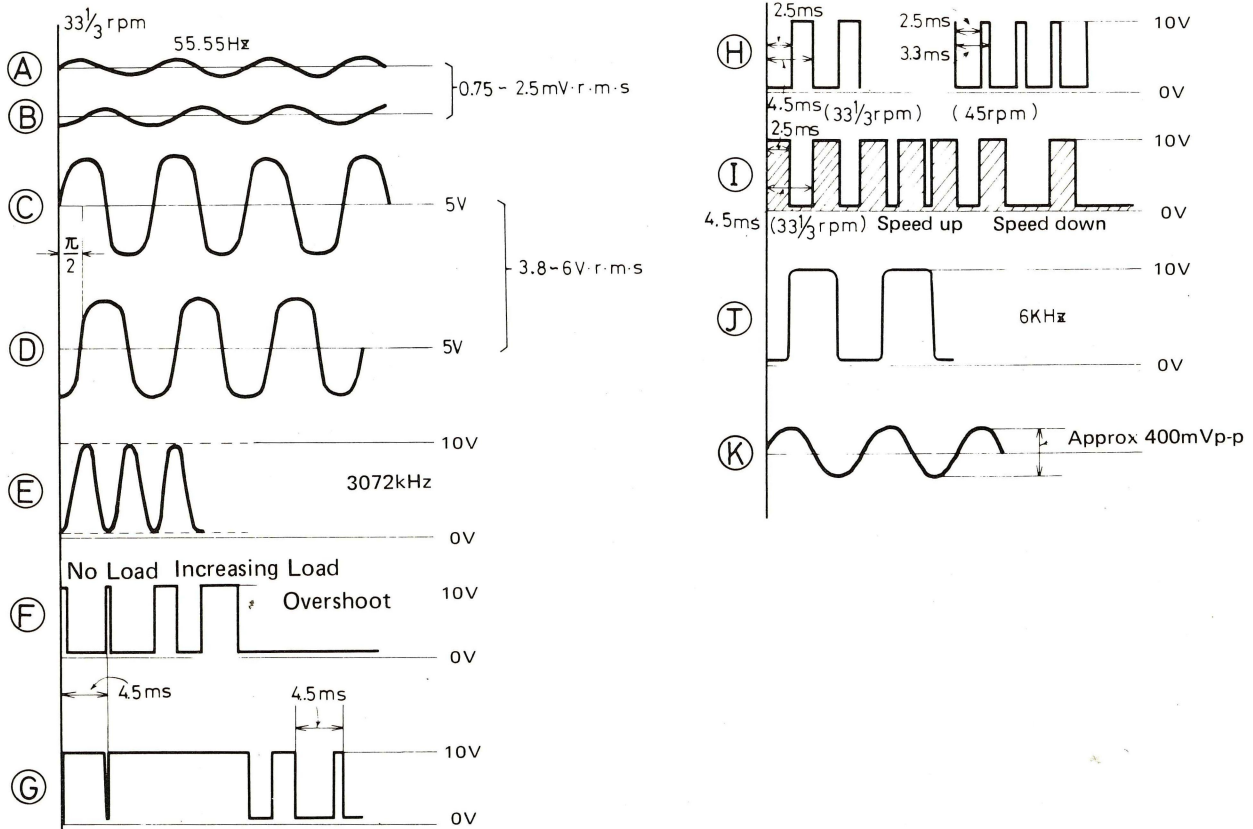

Fig. 29



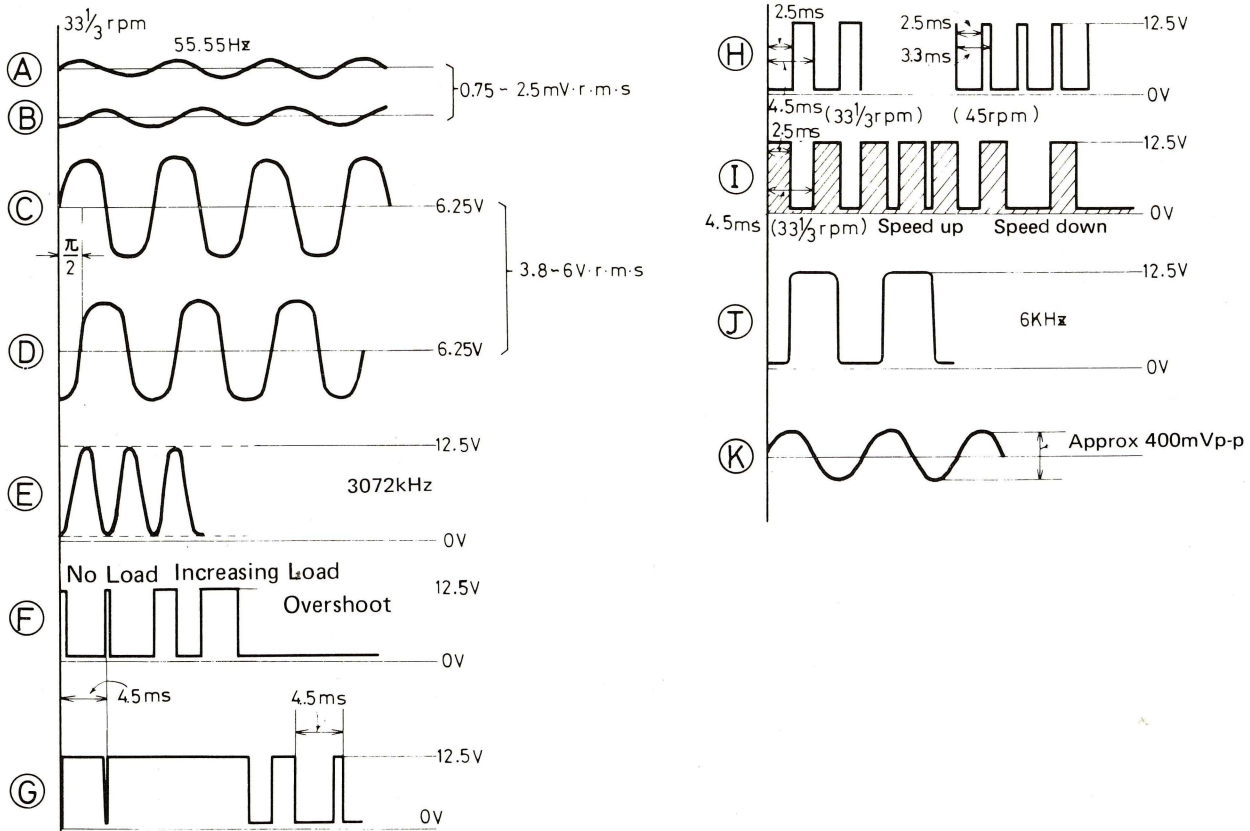
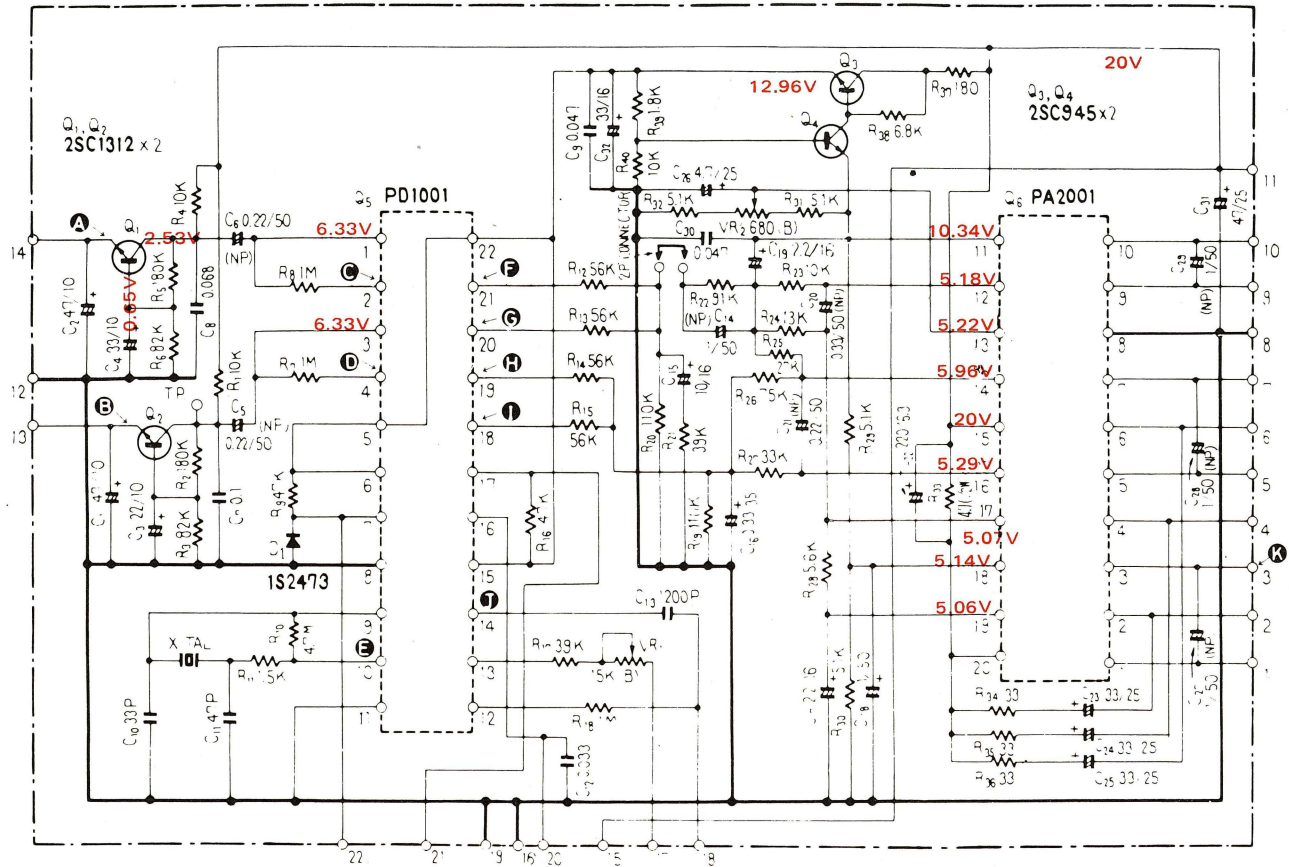

Fig. 30

### 4.3 Trouble shooting guide

#### Steps to be taken

##### 1) Motor does not rotate

The troubleshooting steps to be taken when some of the more common problems occur are listed below. By following the steps in the given order, efficient troubleshooting will be ensured.

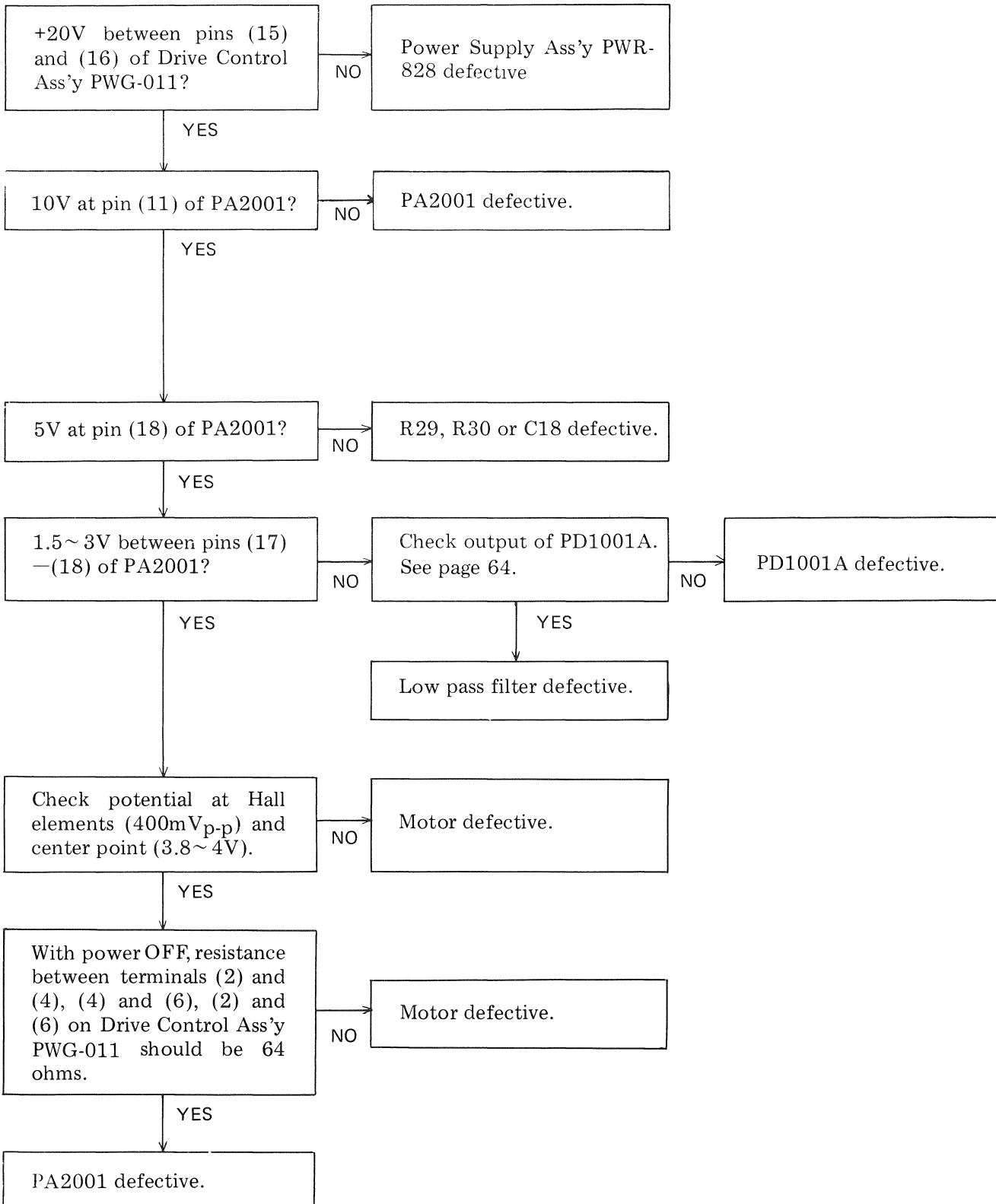

2) Motor run-away

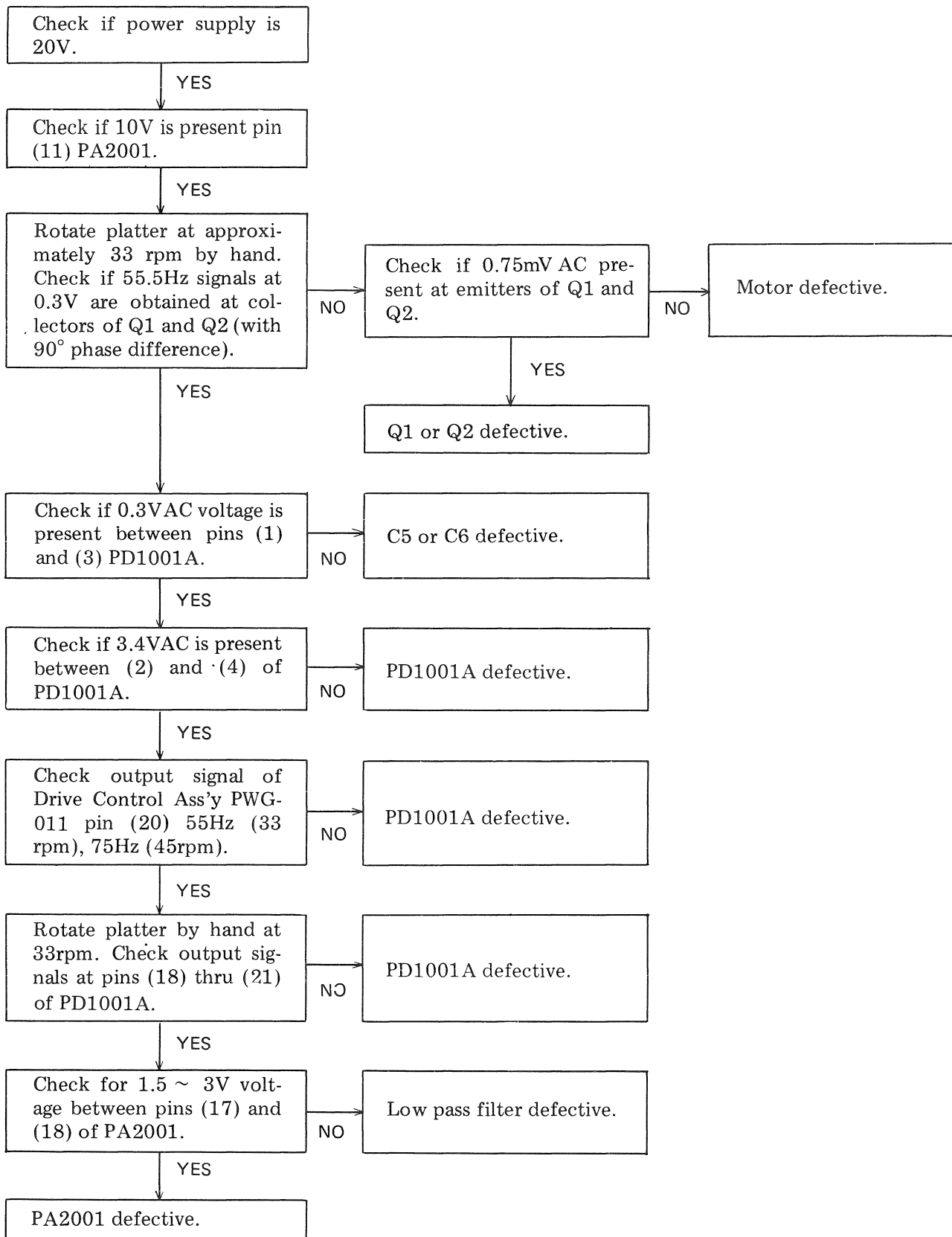

3) Motor alternates between forward and reverse rotation

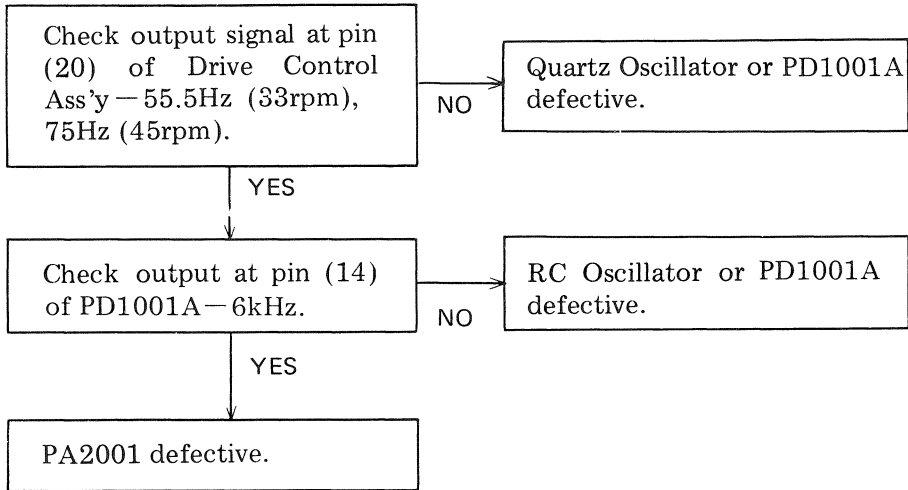

4) Unstable rotation near rated speed

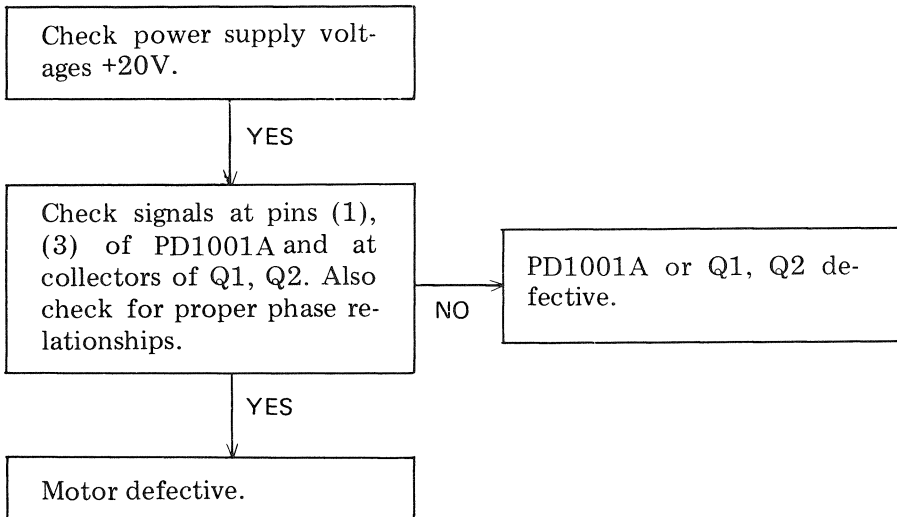

#### 4.4 Readjustment

##### 1) Operation adjustment of the PA2001

The operating points of the PA2001A must be re-adjusted everytime parts are replaced, particularly the CR components in the PA2001, lowpass filter or voltage regulator, or whenever the power supply circuit is repaired.

1. Turn the QUARTZ LOCK ON, and set to 33-1/3 rpm
2. Remove the connector on the drive control assembly
3. Fine adjust the semi-fixed resistor (VR2 white-colored) on the assembly unit until the strobo grooves appear stationary (see Fig. 31)

**Note:** The output from the phase comparator is set at zero when the input signals are in phase, and the rotor speed is controlled at the precise rated speed when the comparator output is zero.

The PLL circuit has an operational range of  $\pm 180^\circ$  out-of-phase which will lock the rotor speed at that which it is rated providing the phase error in the two signals is within this limit. It is necessary to disconnect the connector before adjusting the VR2, otherwise, it may not be possible to adjust the PLL circuit to the center of the locking range (phase error zero).

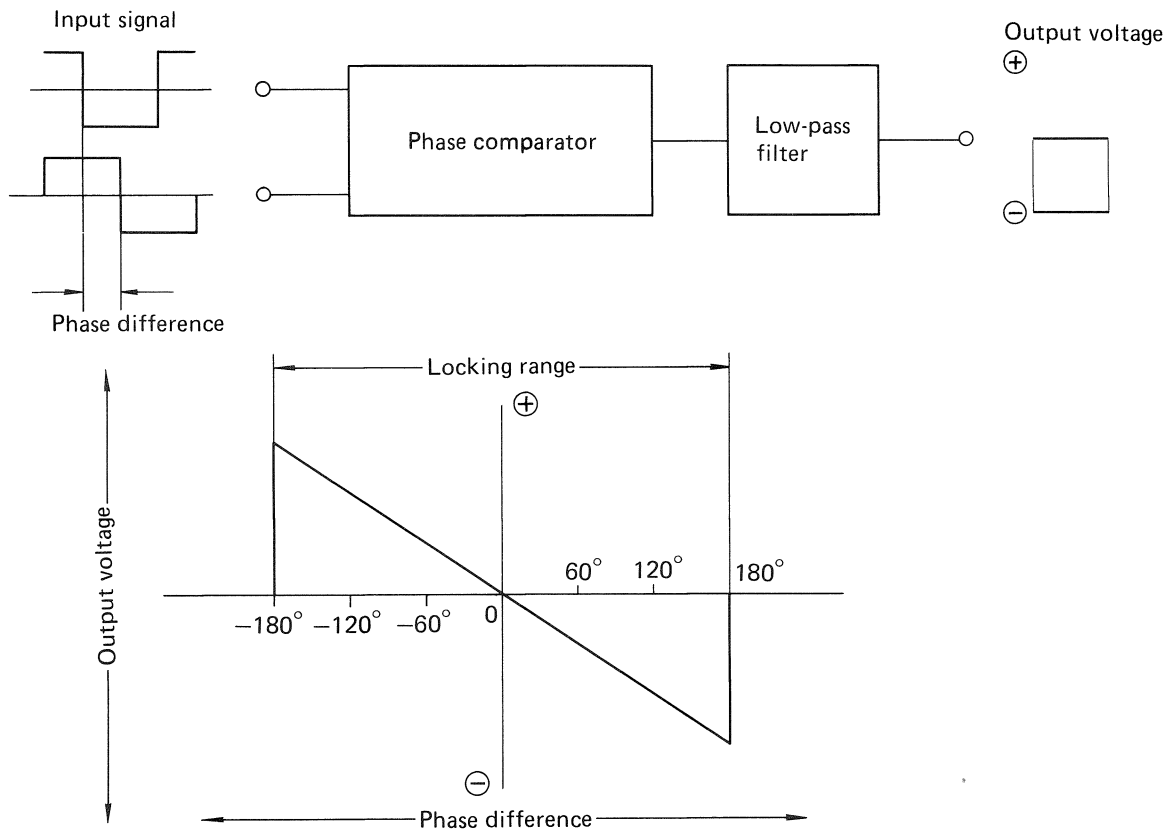

Fig. 31 Phase comparator operation

2) Rotor speed adjustment at QUARTZ LOCK OFF  
If the time constant element (C or R) in the RC oscillator circuit is replaced, it may not be possible to attain the rated rotor speed with the speed adjuster in the center position with the QUARTZ LOCK OFF. In which case, the following adjustment sequence must be carried out:

1. Set the speed adjuster to its mechanical center position
2. Turn the QUARTZ LOCK OFF
3. Fine adjust the semi-fixed resistor (VR1 blue-colored) on the drive control assembly until the strobo grooves appear stationary (see Fig. 33).

40

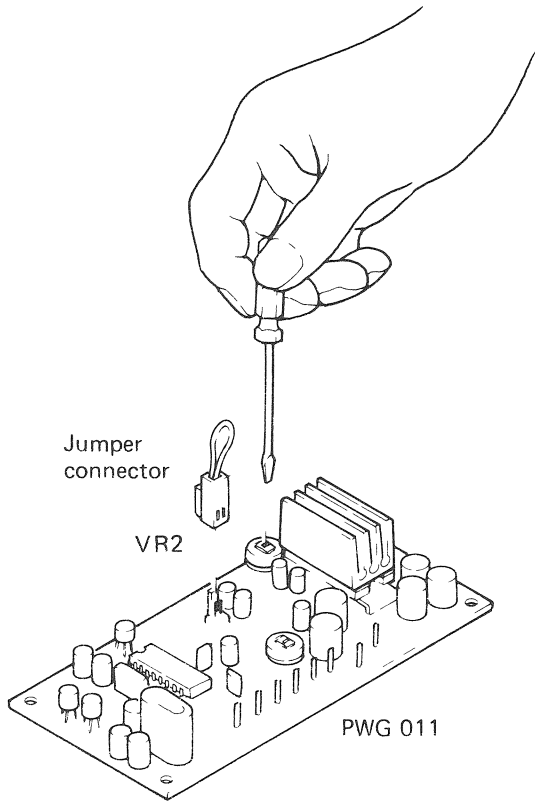

Fig. 32 Adjustment of VR2

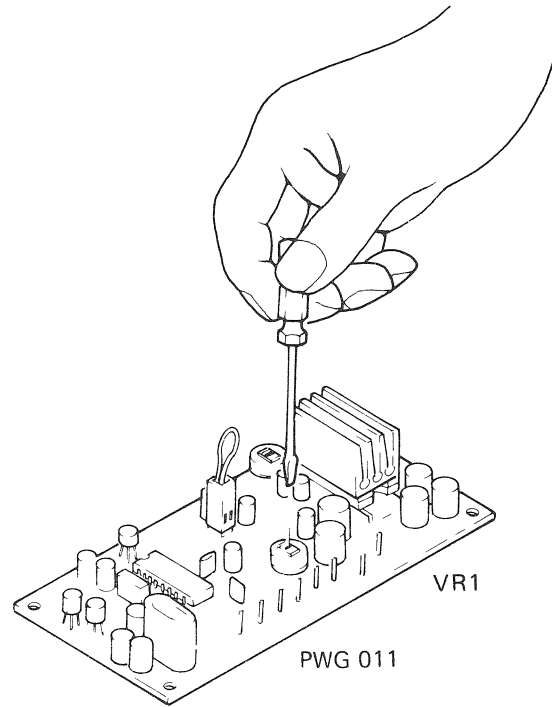
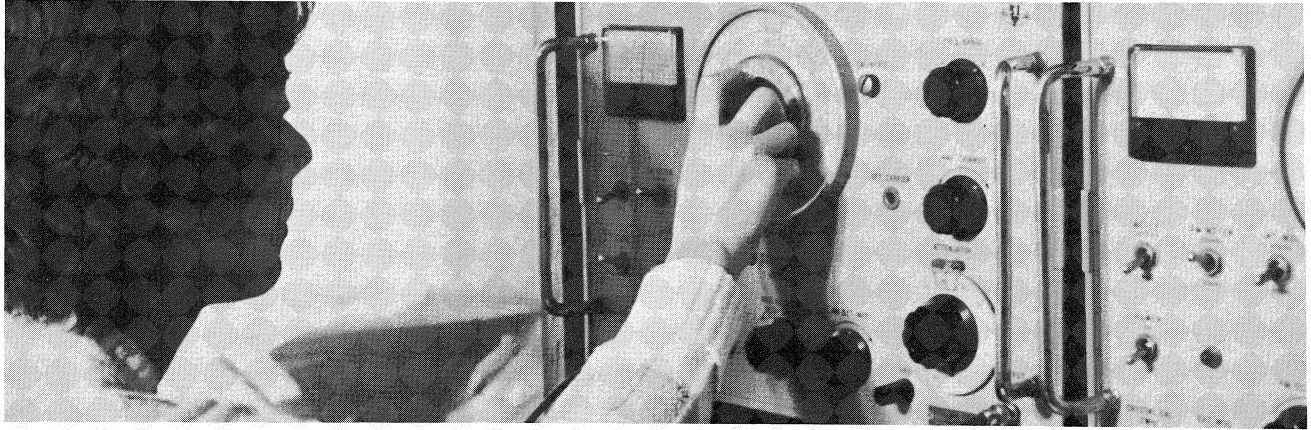

Fig. 33 Adjustment of VR1

# One-Point Servicing Techniques (2)

## Tracking Adjustment



The second in the series of One-point Servicing Techniques deals with the tracking adjustment of tuners, which is frequently encountered in routine servicing.

Compared with audio amplifiers, radio tuners are much more delicately affected by component selection and tuning adjustment. Whenever a component or front-end is replaced in the tuning circuit, complete tracking adjustment must be carried out.

Since this is a frequent and important part of every service engineer's job, let's take a closer look at the theory and practical aspects of the procedure.

41

### 1. Why tracking adjustment is necessary

In order to understand why tracking adjustment is necessary, a basic knowledge of a superheterodyne radio receiver is required. A typical block diagram of this type of receiver is shown in Fig. 1.

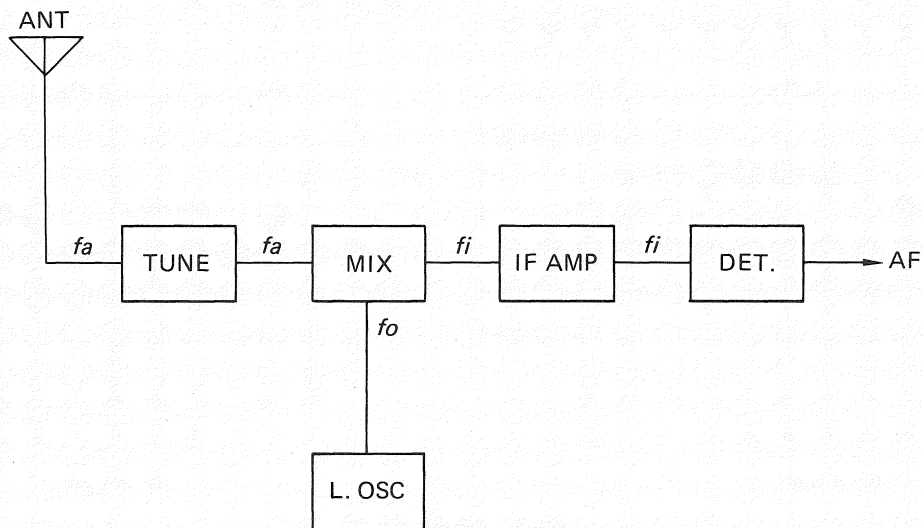

Fig. 1 Block diagram of superheterodyne receiver

In a superheterodyne receiver, a desired radio wave received by the antenna is converted into an inter-

mediate frequency (IF) signal, and the converted IF signal is amplified and then detected (see Fig. 2).

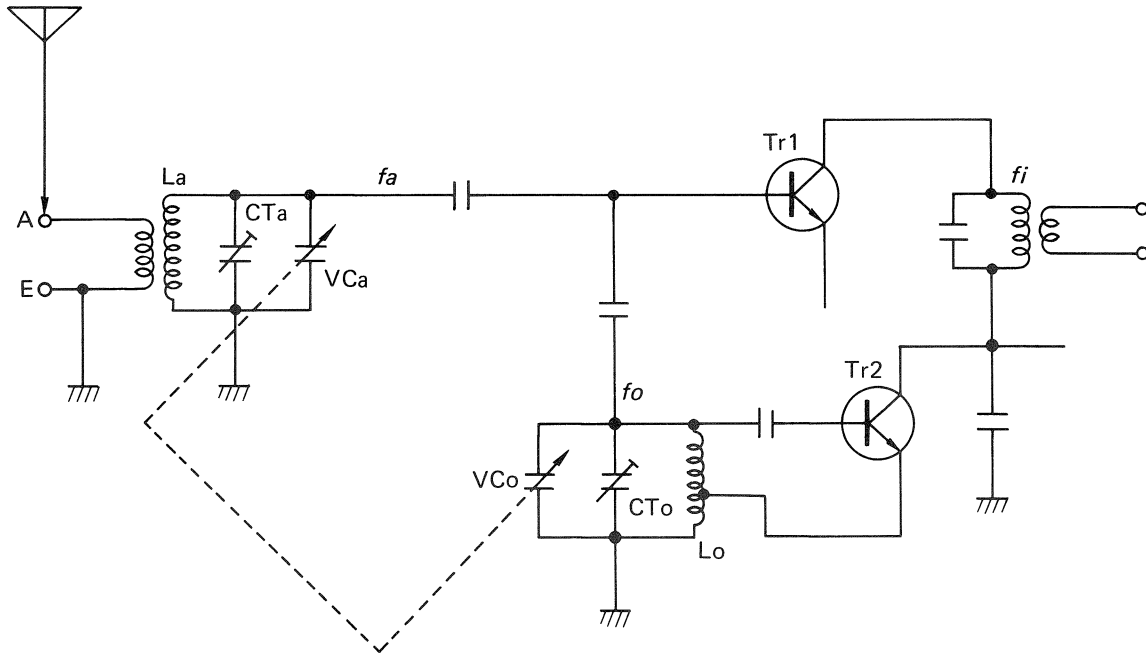

Fig. 2 Frequency converter

42

Many broadcast frequencies are picked up by the antenna, and the desired signal  $f_a$  is selected by the tuning circuit which consists of  $L_a$ ,  $VC_a$  and  $CT_a$ . The selected signal is then supplied to the base of the mixing transistor  $Tr_1$ .

On the other hand, the local oscillator, which is composed of  $Tr_2$ ,  $L_o$ ,  $VC_o$  and  $CT_o$ , generates an  $f_o$  signal which is also supplied to the base of transistor  $Tr_1$ .

This results in many signal frequencies collecting at

the base of  $Tr_1$ , such as  $f_a$ ,  $f_o$ ,  $f_o + f_a$  and  $f_o - f_a$ . However, since the collector load is tuned to the IF frequency  $f_i = (f_o - f_a)$ , only the component of  $f_o - f_a$  appears at the collector.

But here, there is a problem.

And that is, that the frequency difference  $(f_o - f_a)$  is not necessarily constant, and an error  $\Delta f$  to  $f_i$  appears in the actual receiver (see Fig. 3). This  $\Delta f$  is called tracking error.

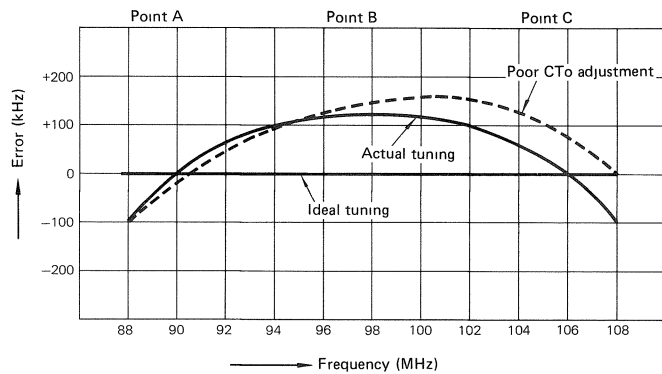

1) FM tuner

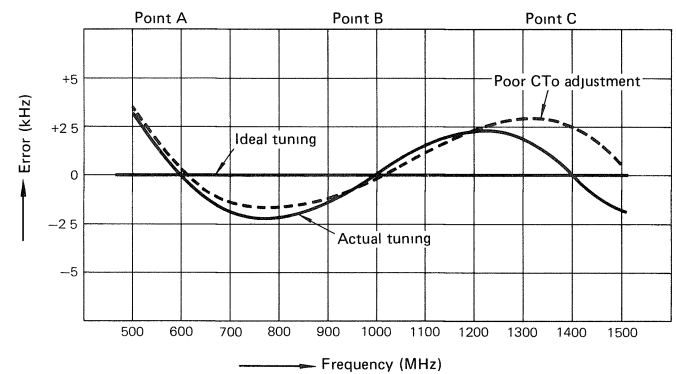

2) AM tuner

Fig. 3 Tracking error



When the tracking error is large, receiver sensitivity deteriorates, and the actual frequencies received do not correspond with the markings on the dial scale indicated by the dial pointer.

The extent of the error depends on the intermediate frequency  $f_i$  and the crossing frequency at which the error is zero. The lower crossing point is called point A, while the higher one is referred to as point C.

After careful consideration of all the technical factors, the intermediate frequency  $f_i$  has been established at 10.7MHz for FM and 455kHz for AM. In addition, the crossing frequencies are usually set

at 90 and 106MHz for FM and 600 and 1,400kHz for AM. All receivers are designed so that the tracking error is minimal when the unit is adjusted to zero-error at these frequencies. It must be noted, however, that in some cases, the frequency of point A may differ.

The adjustment necessary to obtain zero-error at these frequencies is called tracking adjustment, and is performed by adjusting the coils and trimmer capacitors in both the antenna and local oscillator tuning circuits.

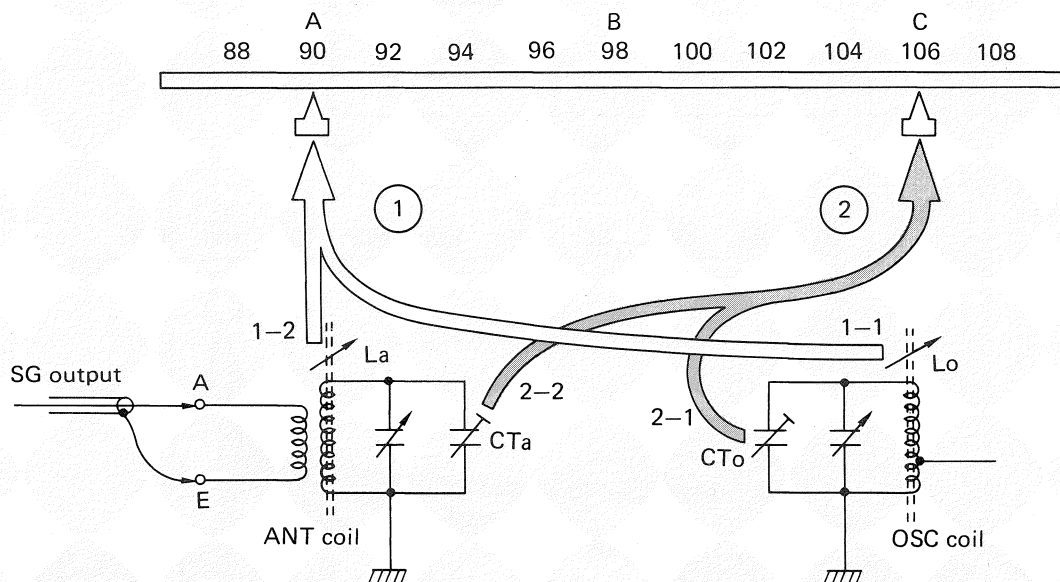

Fig. 4 Tracking adjustment

## 2. Practical tracking adjustment

Even the cheapest tuners have at least four adjustment points, which are at  $L_a$ ,  $CT_a$ ,  $L_o$  and  $CT_o$  (see Fig. 2). While high grade tuners, on the other hand, have ten or more. In both cases, tracking adjustment must be carried out according to the following procedure.

The first step in tracking adjustment is the tuning of OSC coil  $L_o$  and ANT coil  $L_a$  at the lower tracking point A, followed by adjustment of the OSC trimmer capacitor  $CT_o$  and ANT trimmer capacitor  $CT_a$ . At tracking point A, the receiver is tuned to 90MHz to receive a 90MHz FM signal from the FM signal generator. Core  $L_o$  is then turned until maximum AF output is obtained from the receiver, after which the same procedure is applied to core  $L_a$ .

Next, the receiver is tuned to 106MHz at tracking point C to receive a 106MHz FM signal. Capacitor  $CT_o$  is then adjusted until maximum AF output is obtained, after which the same procedure is applied to capacitor  $CT_a$ .

Since adjustment of capacitors  $CT_o$  and  $CT_a$  affects

the frequency at which point A is set, the process is repeated two or three times to ensure complete tracking adjustment.

As for AM tracking adjustment, the frequencies at points A and C are, naturally, different. But the procedure is exactly the same. However, it must be remembered that the above-mentioned procedure applies only to the simplest of cases. FM tuners, especially, invariably have one or two-stage RF amplifiers, and many are equipped with double-tuning circuits. Moreover, some models have SW and LW bands in addition to AM. Nevertheless, the tracking adjustment procedure remains the same in all cases, only the frequencies at the adjusting points A and C differ. Therefore, once the procedure has been memorized, accurate tracking adjustment of any model, regardless of the number of bands, can be quickly mastered.

A typical example is illustrated by the schematic diagram and adjustment sequence for the front-end of a Pioneer TX-8500II stereo tuner shown in Fig. 6.

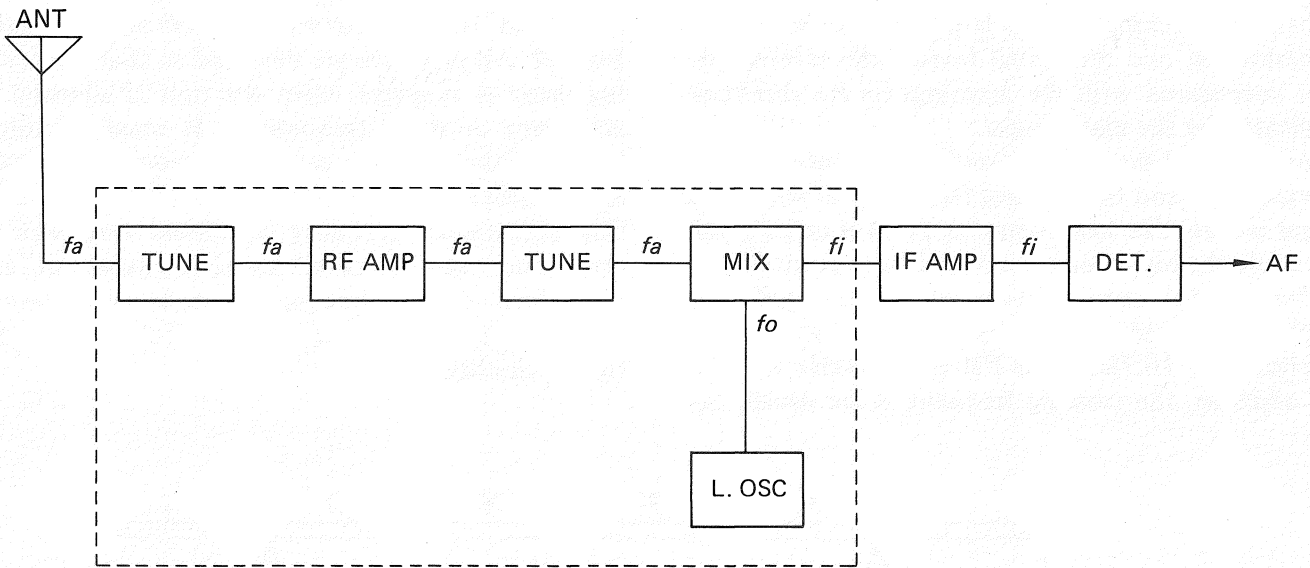

Fig. 5 Block diagram of TX-8500II (FM front-end)

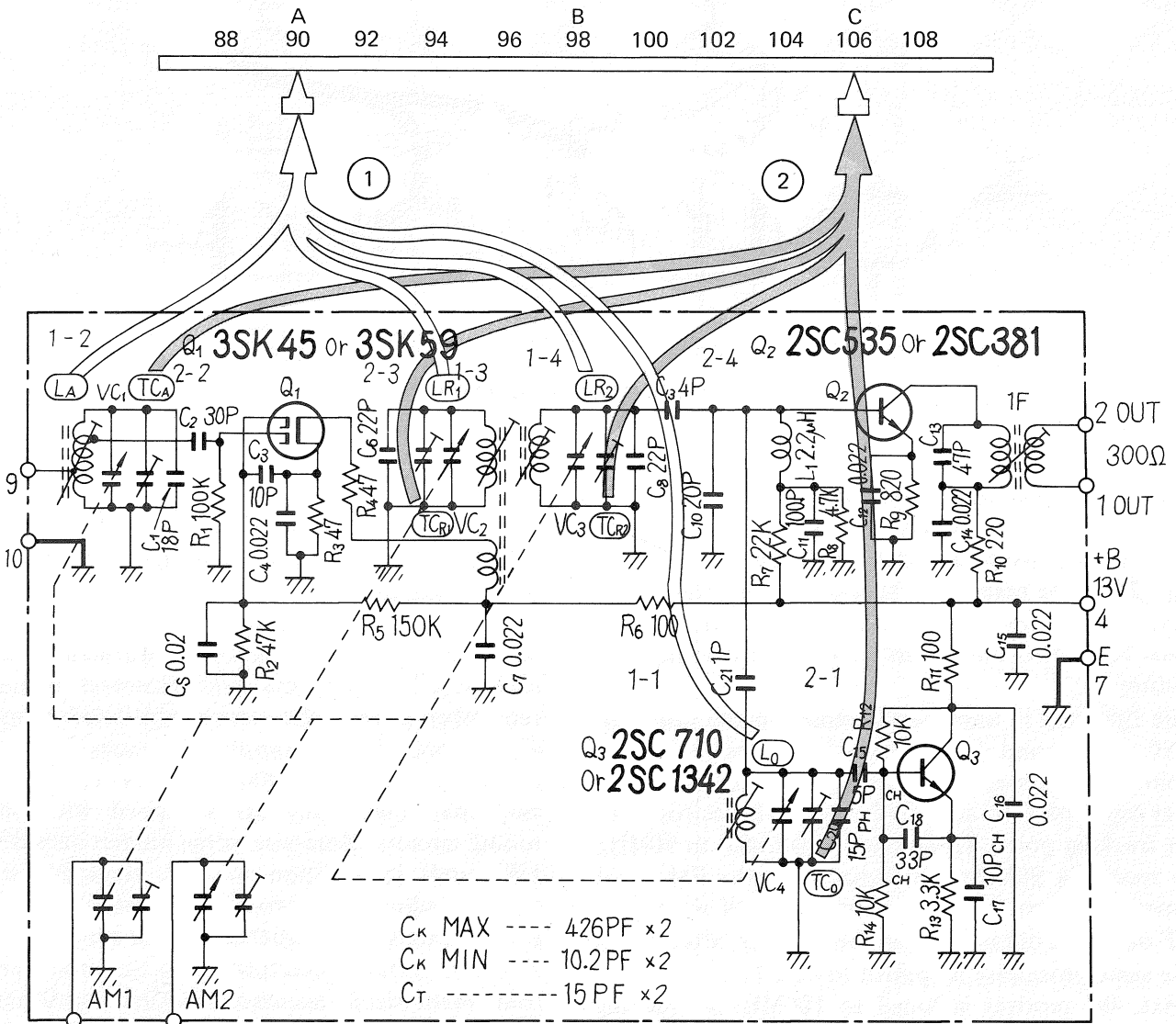

Fig. 6 Adjustment sequence for TX-8500II FM front-end

The set-up for measuring FM tracking adjustment is shown in Fig. 7. Here, the FM signal generator is set at 400Hz with 100% modulation and an output of 10dB. For AM tracking adjustment, the instruments must be set up as shown in Fig. 8, with the AM

signal generator set at 400Hz with 30% modulation and an output of 30dB.

In the case of AM circuits, the bar antenna corresponds to the ANT coil  $L_a$  in Fig. 2.

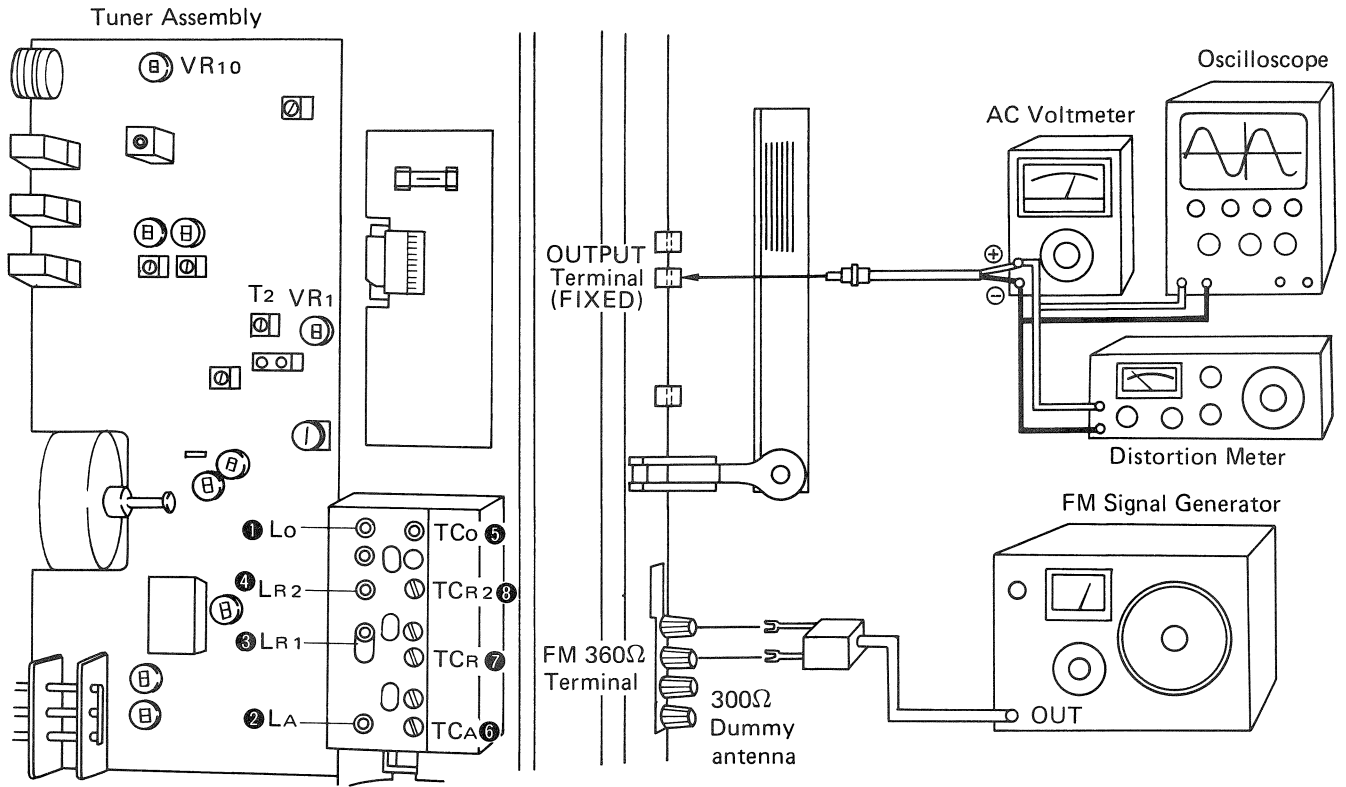

Fig. 7 Set-up for FM tracking adjustment

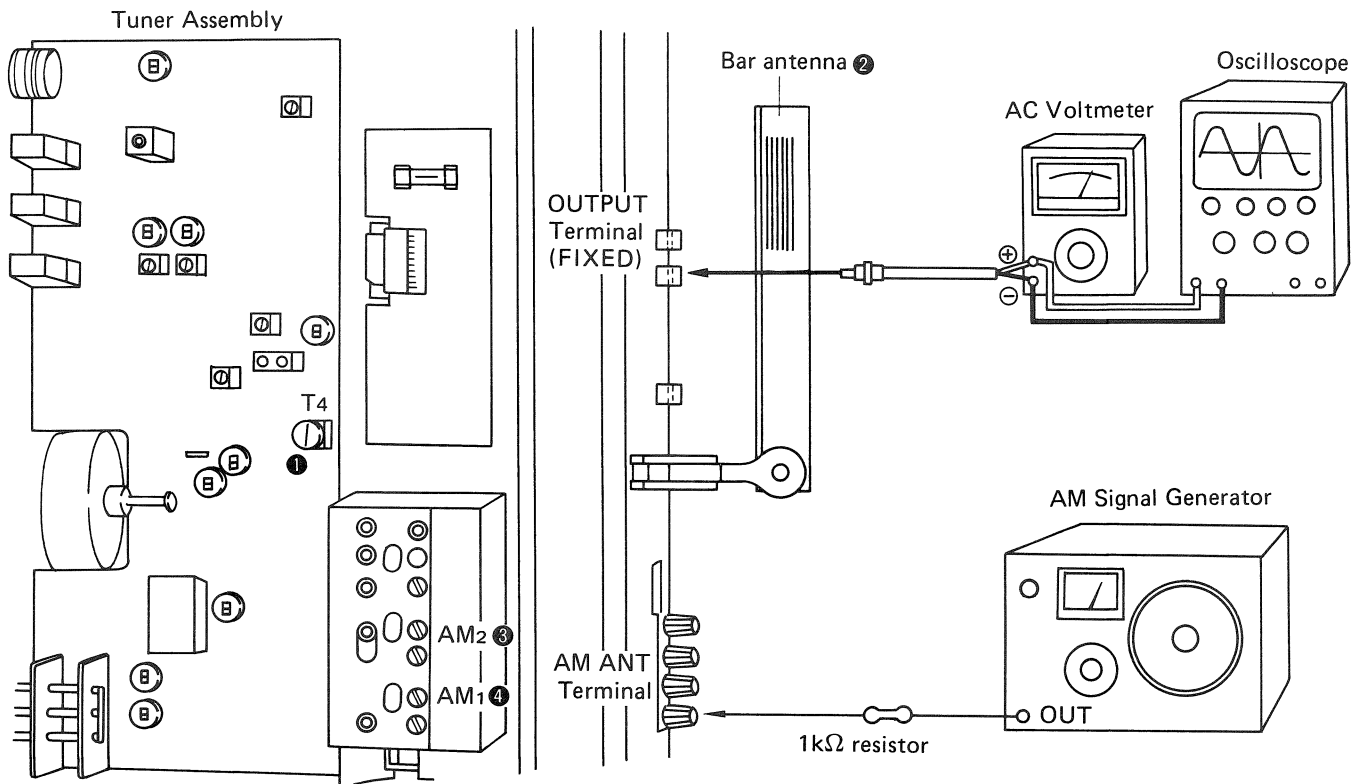

Fig. 8 Set-up for AM tracking adjustment

### 3. Adjustment precautions

1. To ensure accurate tracking adjustment, the signal generator and receiver or tuner must be left on to age for about thirty minutes. Aging is very important when adjusting RF circuits, especially on FM.
2. When a service manual is not available, it is important to set the SG output very carefully as the testing signal level to be applied to the antenna is unknown. Before commencing adjustment, the SG output should be set so that the signal meter of the tuner or receiver indicates  $1/3$  or  $1/2$  full scale. When making adjustments, the signal meter should be monitored, and if it indicates more than  $1/2$  full scale, the SG output should be decreased to give  $1/3$  deflection, and the adjustment repeated.
3. In cases such as SG failure or field servicing, when a signal generator is not available, a simple test oscillator or broadcast signal can be used instead. When a test oscillator is used, dial setting must be done very carefully since the test oscillator output contains high harmonic components. For this reason, the output level of the test oscillator should be set as low as possible.

When a broadcast signal is used, the two closest signals to tracking points A and C should be selected. Adjustments are then made in the same manner as before.

Naturally, in this case, the tuner or receiver must be tuned to the broadcast signal frequencies, and care must be taken not to make excessive antenna input adjustments.

In both the above cases, adjustment is rough, and the tuner or receiver will not deliver optimum reception. There will be no problem so long as the user only listens to strong or local stations, but, reception of weak or distant stations will be poor.

# Measuring Instruments (2)

## Multimeters—2

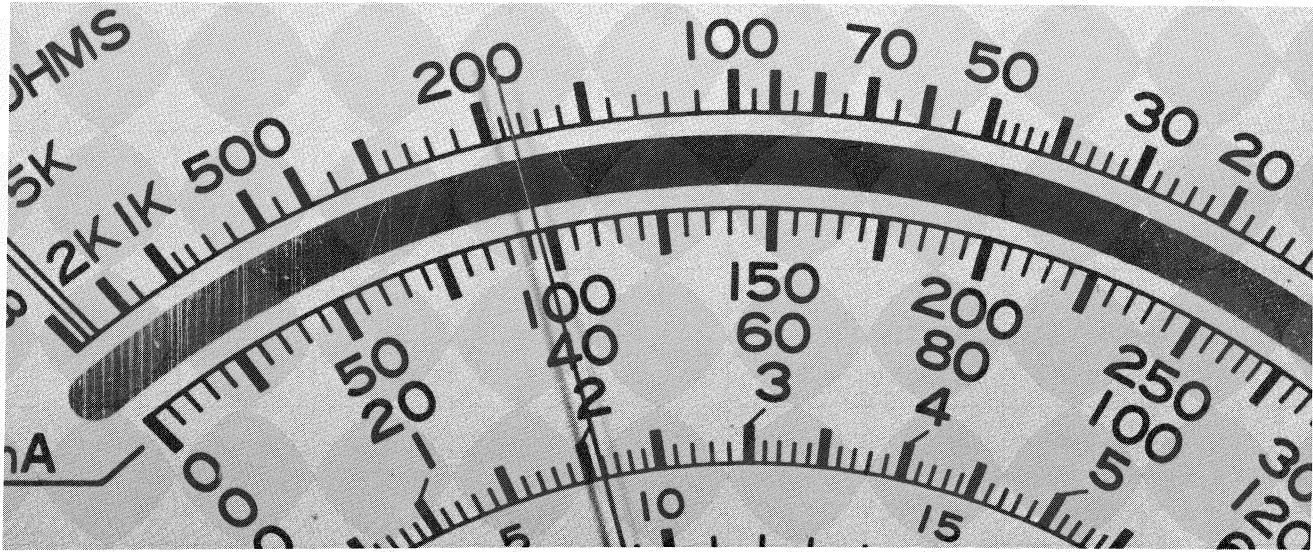

### Testing Parts with a Multimeter

In this issue, quality checking of electronic parts using the ohm range of a multimeter will be discussed. However, before going into the details of the actual checking method, let us first explain the basic principle and use of the ohmmeter.

#### 1. Principle of the Ohmmeter

The system for utilizing a multimeter as an ohmmeter is shown in Fig. 1.

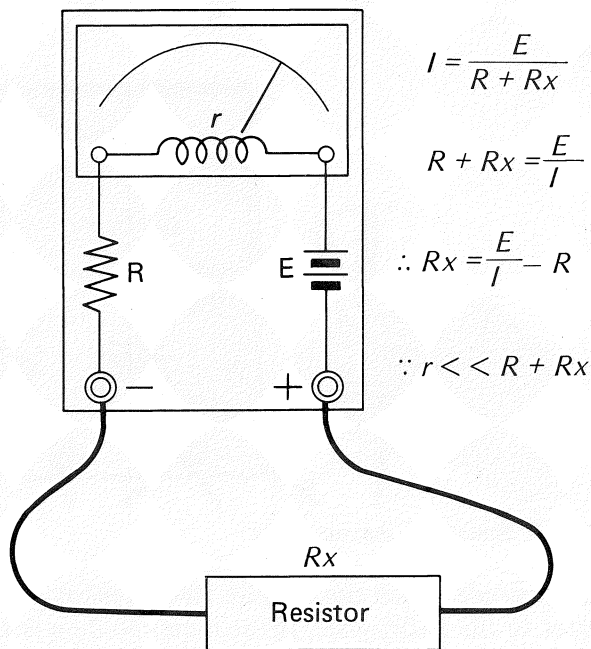

Fig. 1 Multimeter circuit when measuring resistance

Since the meter of a multimeter is an ammeter, by simply connecting a resistor to it, the resistance can be measured by checking the current flow in accordance with a reference voltage using Ohm's law. That is, the resistance value is calculated by the equation  $R_x = \frac{E}{I} - R$ .

This means that the value of a resistor can be easily measured by simply calibrating the multimeter scale in the appropriate resistance values. And that is the principle of the ohmmeter.

An actual multimeter utilizes a highly sensitive meter and/or a layer-built cell. It also has resistors built into the circuit which enable a 3 to 4 range shift, which effectively widens the meter's measuring range (see Fig. 2).

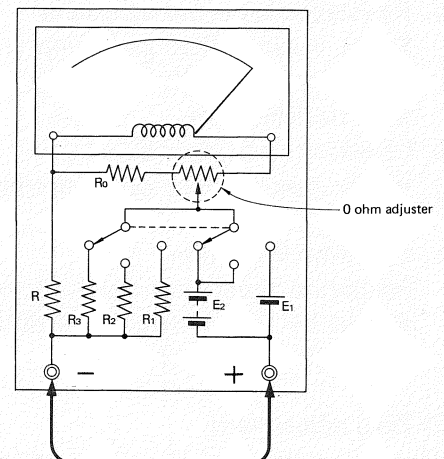

Fig. 2 An actual multimeter circuit for ohmmeter

The value of each resistor in the meter circuit is not necessarily the same as the actual designed value, and the built-in cell sometimes experiences a drop in voltage. To compensate for this, the multimeter is equipped with an 0 ohm adjuster. It is important to note that 0 ohm adjustment must be made every time prior to conducting resistance value measurements or continuity tests.

As shown in Fig. 1, the plus (+) terminal of the multimeter is connected to the minus (-) terminal of the battery, and positive voltage appears at the minus terminal of the multimeter. Try to remember this fact, since it is common to all multimeters, because you will need it when you start to test diodes, transistors, and other semiconductors.

## 2. How to Use an Ohmmeter

### 1) Selection of measurement range

Usually multimeters have x1, x10, x100, x1000 or x1, x100, x1K, x10K ranges. The selected range multiplies the indicated value (R) on the scale by the corresponding amount mentioned above. For example, if the meter reads 520 and the scale is set at 1K, the measured resistance is 520K $\Omega$ .

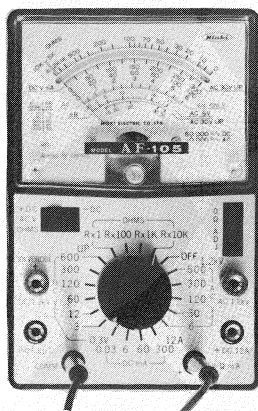

Photo 1 A multimeter

There are three methods to help you determine an optimum range for your purpose:

- a. Resistance value measurement  
Select a range that gives you a meter deflection of more than half. By doing so, you minimize your reading error.
- b. Checking open circuits  
Where you suspect open circuits, use the lowest range (x1).
- c. Checking insulation  
Insulation resistance, short-circuiting, and leakage should be tested with the highest available range (normally x1K or x10K).

### 2) Zero adjustment

The adjustment of the meter to read '0' is necessary before making resistance measurements. Short-

circuit the meter leads as shown in Photo 2, and then fine-tune the zero adjustment knob until the pointer reads exactly 0 $\Omega$  (full scale). This procedure must be repeated whenever you switch to a different measurement range.

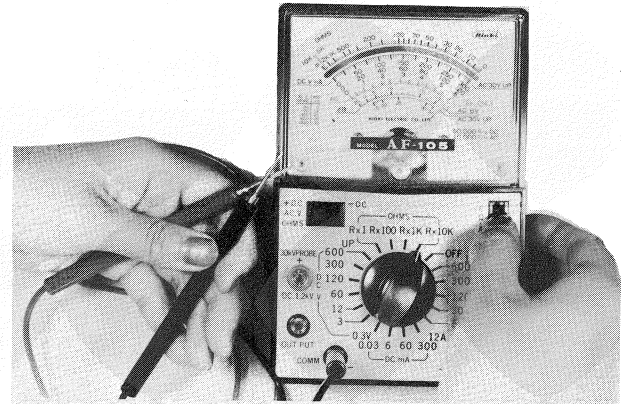

Photo 2 0 ohm adjustment

## 3. Quality Test by Multimeter and Coverage of Measurement by Ohmmeter

- 1) Resistors
- 2) Capacitors
- 3) Switches
- 4) Coils and transformers
- 5) Meters, phono cartridges and tape deck heads
- 6) Diodes
- 7) Transistors
- 8) Variable resistors:

### 1) Resistors Quality Test

In general, defective resistors cause a resistance error or an open circuit. Select an ohm range which matches the resistance value of the resistor under test. This can be determined by reading the color code.

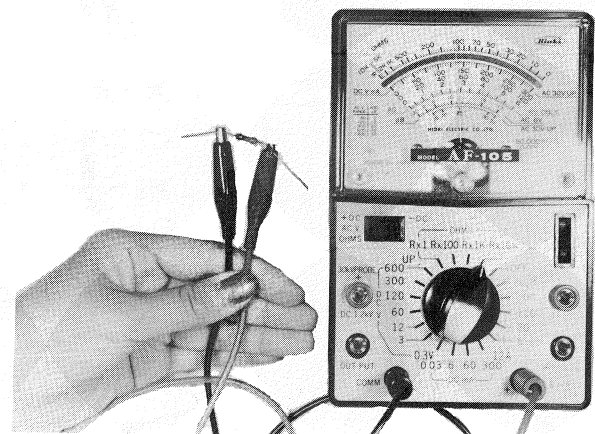

Photo 3 Resistance measurement

For example, when checking an 1M $\Omega$  resistor, set the meter to the x10K scale. If the meter reading is 100, then 100 x 10K is 1M $\Omega$  and the resistor is good (see Photo 3).

## Precautions

### a. Effect of human body

The resistance of the human body can interfere with a correct reading.

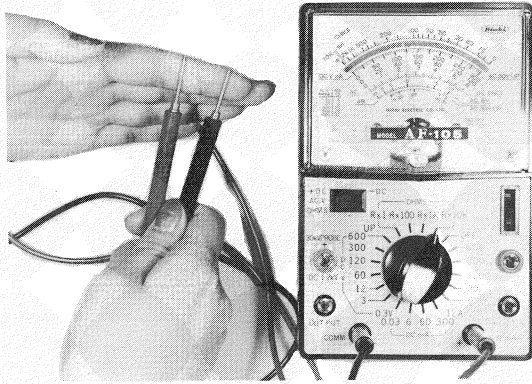
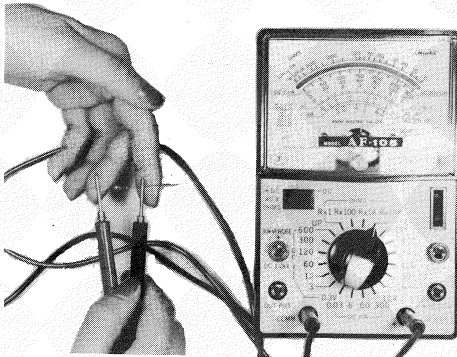
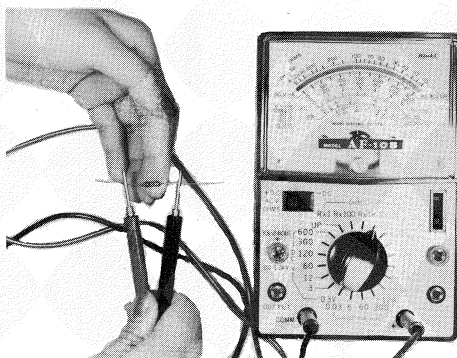

Photo 4 Effect of human body (1)

When measuring resistance you often hold the test leads with your fingers as shown in Photo 5a. The contact of your fingers on the metal portion of the leads can cause an erroneous reading from the meter scale. This is especially true when you are measuring a high resistance, since your body will be within the range of  $100\text{K}\Omega \sim 2\text{M}\Omega$ . Wet or sweaty fingers will alter the value of the measurement if they are allowed to touch the metal portion of the test leads.



a



b

Photo 5 Effect of human body (2)

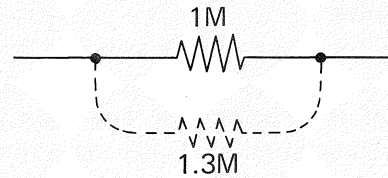

Fig. 3 Equivalent circuit

Let's see what the result would be. Suppose that the actual value of the resistor is  $1\text{M}\Omega$ , and your body resistance is  $1.3\text{M}\Omega$  as shown in Fig. 3. Your body resistance is connected in parallel to the measured resistance, resulting in an inaccurate reading as the following equation shows:

$$R = \frac{R_1 \times R_2}{R_1 + R_2} = \frac{1300 \times 1000}{1300 + 1000} = 565 \text{ (K}\Omega\text{)}$$

The resulting resistance measured at  $565\text{K}\Omega$  is a 43.5% error.

### b. Measurement of very low resistance values

Whenever you measure very low resistance values, take special care to press the tips of the test leads firmly against the component that you are measuring. Failure to do this can result in contact resistance which will again cause a false reading from your meter. Make sure that your test leads are clean when you measure very low resistance. A little oxidation on the metal prongs can cause increased contact resistance.

## 2) Capacitors

### Quality Test

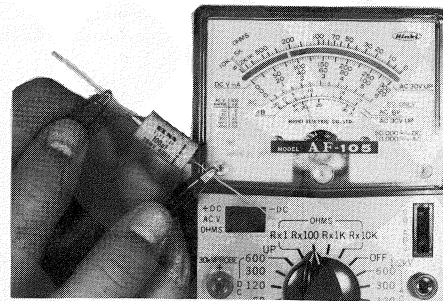

Photo 6 Checking of a capacitor

A defective capacitor will often indicate low insulation resistance or a loss in capacitance. The ohmmeter can be used to check for defective insulation in capacitors from the  $\text{pF}$  to  $\mu\text{F}$  range, and it can also be used to check for complete loss in capacitance in capacitors that are larger than approximately  $0.01\mu\text{F}$ . It should be noted here that an accurate check for capacitance is not possible with an ohmmeter. It can only test whether the capacitance is unusually large or small (by a temporary pointer swing) and it can test for an open capacitor. When checking capacitors, a suitable ohm range according to their capacitance, ( $\times 1$  for large electrolytic capacitors,  $\times 1\text{K}$  or  $10\text{K}$  for small capacitors) should be used.

### Loss in capacitance

An open capacitor can easily be checked by charging up the suspected capacitor with the measurement current of the multimeter, and then reading the charging characteristics of the capacitor (how much the pointer swings). To do this, connect the test leads of the meter to the terminals of the capacitor, as shown in Fig. 5. The measurement current will flow into the capacitor and gradually charge it up. As this happens, the pointer should swing toward the low resistance end of the scale, and then swing back toward  $\infty$  as charging is completed. The farther the pointer swings toward the low-resistance end of the scale the greater the capacitance and the longer the required time for the pointer to swing back to  $\infty$ . In a very large capacitor (more than  $1000\mu\text{F}$ ), there is insufficient measuring current to charge up and the pointer merely returns to  $\infty$ . The pointer swing and capacitance value relationship is shown in Fig. 4. If the pointer doesn't deflect at all, you can assume that the capacitor is open.

50

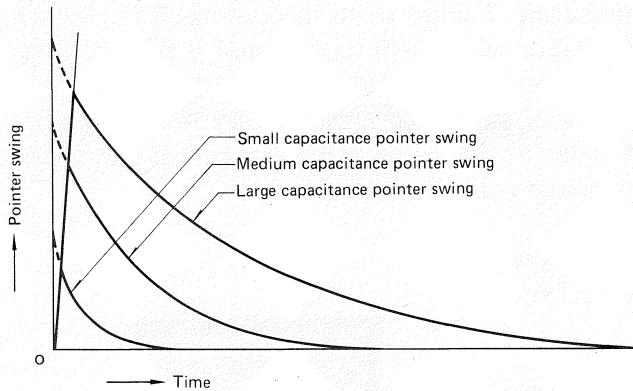

Fig. 4 Relationship between the pointer swing and capacitance

### Defective Insulation

When fully charged, a capacitor should permit no flow of DC current from the battery of a multimeter. This phenomenon can be used to check for defective insulation in small and medium-sized capacitors. As we have mentioned before, a large capacitor cannot be sufficiently charged to use this principle. To check a smaller capacitor (less than  $1\mu\text{F}$ ) for proper insulation, attach the leads and wait for the capacitor to charge. If the meter indicates a resistance of, let us say,  $100\text{K}\Omega$  or  $1\text{M}\Omega$  for an extended period of time, then we can consider the insulation on that capacitor to be defective.

### Precautions

- Electrolytic capacitors are marked for polarity, and care must be taken to see that it matches the electrical polarity of the multimeter (see Fig. 5).

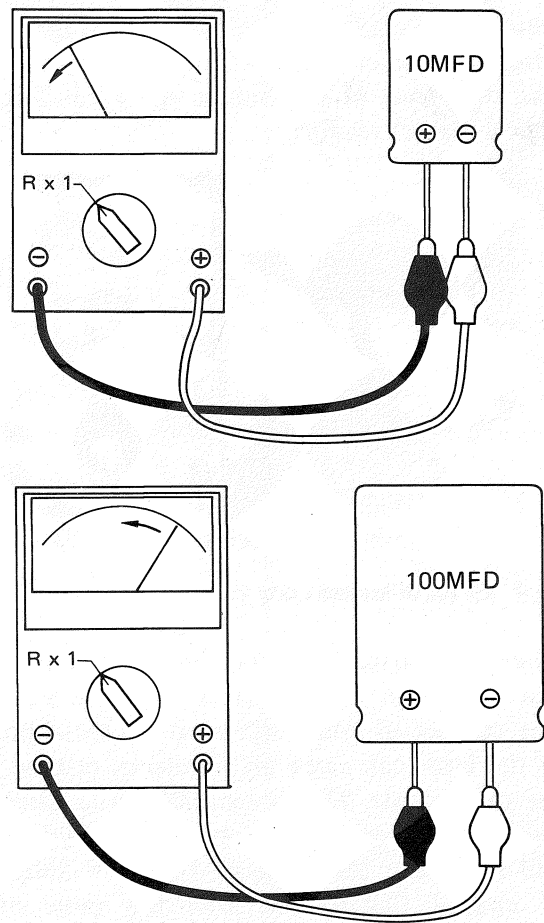

Fig. 5 Capacitance check

- Some multimeters, often good ones, have 9V or 22.5V internal batteries for measuring resistance at the highest ohm range (x 1K). If you should happen to measure a low voltage capacitor (particularly electrolytics) with one of these high voltage meters, insulation breakdown may well result. To avoid this, use the x100 scale in such a situation.

### 3) Switches Quality Test

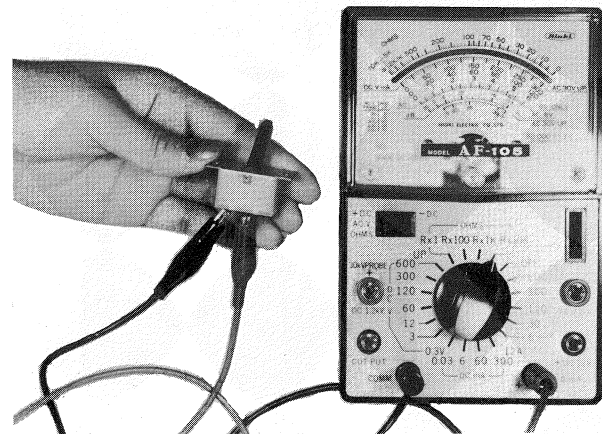

Photo 7 A defective switch shows some resistance



Most defective switches have defective contact resistance. Since the contact resistance of switches is normally less than  $10 \sim 20\text{m}\Omega$ , it is beyond detection. Extensively used or infrequently used switch contacts may become extremely bad due to surface corrosion, while normal contacts exhibit almost  $0\Omega$  resistance.

#### Precautions

Often it is possible to relieve the condition just mentioned by quickly turning the switch on and off until it appears to work properly. This remedy, however, is often temporary and should not be relied upon.

### 4) Coils and transformers

#### Quality Test

A defective coil or transformer is usually indicated by the following circuit conditions: open circuit, lowered insulation resistance, or layer-short. The test for a layer-short is beyond the capability of a multimeter.

#### Open Circuit

Check the resistance values across the leads or terminals of any winding or coil that you suspect may be open. A normal winding will give a low resistance reading. A defective coil or winding that is open will register infinite ( $\infty$ ) resistance.

#### Insulation Resistance

Set the ohm range to the highest setting and touch one lead to one of the leads or terminals and the other to the case of the coil or transformer. If there

has been a breakdown in the insulation, you will get a resistance reading of some kind, depending on the degree of the fault. A correctly operating component will read  $\infty$  on the ohm scale of the meter.

### 5) Meters, phono cartridges and tape deck heads

Meters, phono cartridges and tape deck heads can also be quality tested by checking the conductivity of the coil using a multimeter. But a careless check may result in the following defects if the checking current is too high for these components:

#### a. Meters

The meter pointer may become bent or stuck.

#### b. Phono cartridges

The core of the windings may become magnetized, or the permanent magnet of the stylus may be weakened.

#### c. Tape deck heads

The head core may become magnetized.

Concerning a and b, magnetization of the core causes noise, distortion, and output drop out, especially at high frequencies. To avoid damage or deterioration of quality, checking of these components must be done at the highest range of the multimeter ( $\times 1\text{K}$  or  $\times 10\text{K}$ ). Also, checking must be finished as quickly as possible in order not to magnetize any of the components.

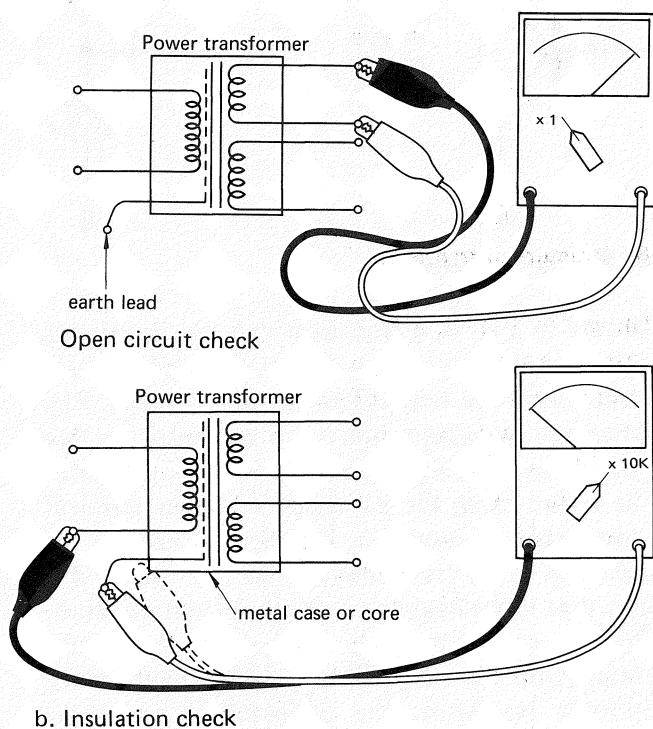

Fig. 6 Checking of the transformer

## 6) Diodes

### Quality Test

The primary symptoms in a defective diode are: short circuit, open circuit, and deterioration of characteristics. This latter condition cannot be checked with an ohmmeter. So we will limit our discussion to the detection of open and short-circuit conditions.

### Open and Short Circuits

In this area, a diode can be checked with the following procedure (see Fig. 7).

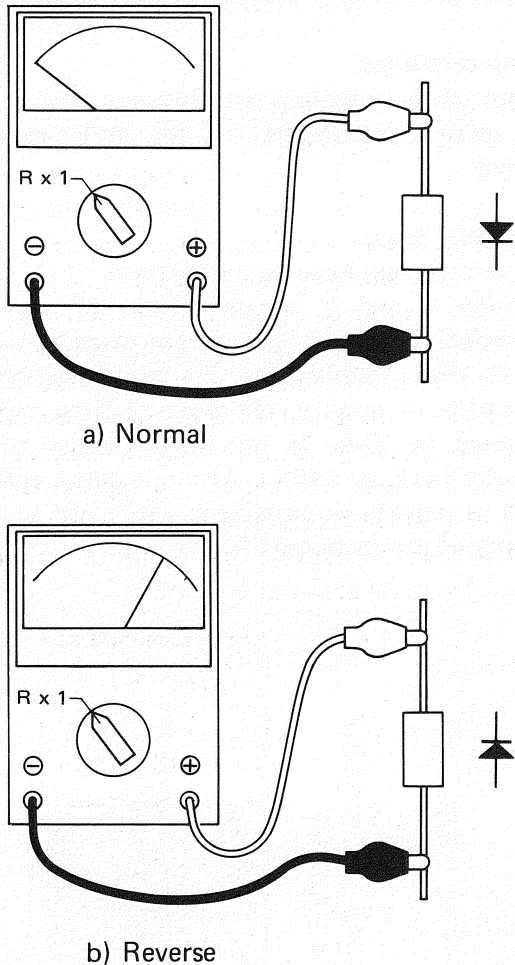

Fig. 7 Insulation resistance check

Note that typical resistance values differ with each multimeter and the type of diode under test; for example Germanium (Ge) and Silicon (Si), as shown in Table 1. Also note that the resistance values differ with the measurement range used on the ohmmeter. Unlike fixed resistors, diodes do not permit a current flow proportional to the applied voltage. In any case, the meter indicates  $0\Omega$  resistance if the diode under test is shorting. Also, if the diode is open, the meter indicates  $\infty\Omega$  resistance even at the forward direction of the measuring current. When a Ge type diode is measured on the high-ohm range, the reverse leakage current in the diode will produce a high resistance value ( $1M\Omega$ ).

Type of diode	Measurement range	Normal	Reverse
Ge	x1	60 ~ 80 $\Omega$	$\infty$
	x1K	1 ~ 3K $\Omega$	500K ~ 1M $\Omega$
Si	x1	20 ~ 30 $\Omega$	$\infty$
	x1K	5 ~ 10K $\Omega$	$\infty$

Table 1 Resistance values of Ge & Si type diodes

## 7) Transistors

### Quality Test

Defective transistors are usually indicated by any of the following symptoms: short circuit, open circuit, high noise, lowered operating characteristics. Quality testing of a transistor with a multimeter is confined to open and short circuit faults.

### Open and Short Circuit

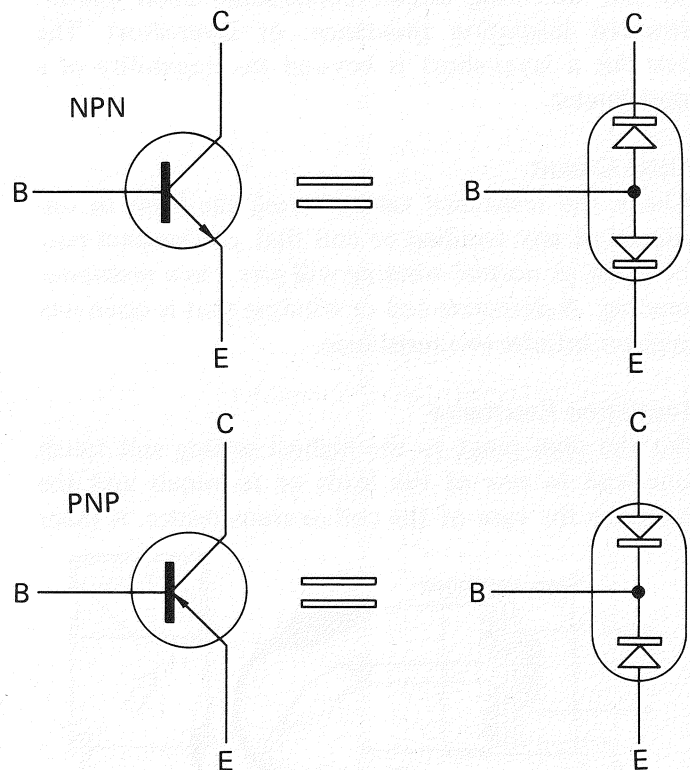

Fig. 8 Structure of transistors

As shown in Fig. 8, a transistor can be considered, for test purposes, to be two diodes. Generally speaking, transistors are best tested in the x1 range. Fig. 8 shows the representation of a transistor as two diodes. In the following example, an NPN transistor will be tested using the x1 range. To begin, connect the test leads as shown in Fig. 9, and change the positive test leads (remember from our earlier discussion that it has negative potential) from the emitter to the collector, holding the base at positive potential (with the negative test lead). In a properly functioning transistor, the base-emitter and base-collector resistances should read somewhere in the neighborhood of 20 ~ 40 $\Omega$ . Resistance values differ

to some degree with each multimeter and transistor under test. After this measurement, reverse the polarity of the test leads and repeat the procedure (Fig. 10). The resistances should now increase to infinity.

If the base-to-emitter or base-to-collector resistance in Fig. 9 or 10 is zero, the junction is short circuited. On the other hand, if the forward resistance (Fig. 9) is infinite, the junction is open. If the base-to-emitter and base-to-collector resistances are zero, not surprisingly, the trouble here is a shorted collector and emitter, a condition often found in power transistors.

To check PNP transistors, use the reverse polarity of the test leads from the procedure followed for NPN types.

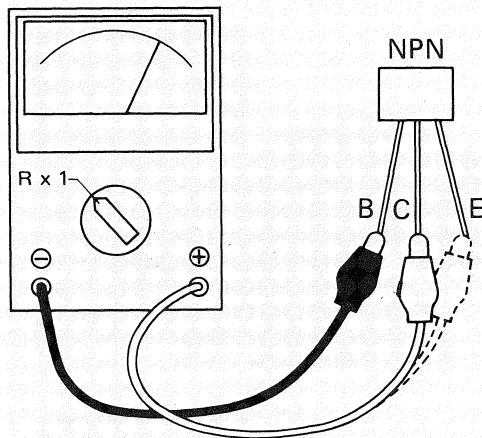

Fig. 9 Testing of an NPN transistor

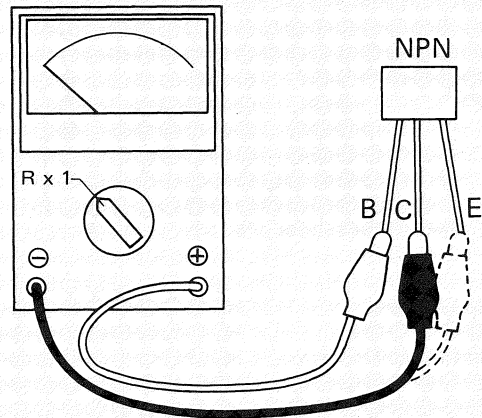

Fig. 10 Testing of an NPN transistor

**Precautions**

The same precautions apply here as those given for the testing of fixed resistors.

**How to Identify the Base, Emitter, and Collector**

**1. The Base**

As already described, checking the quality of a transistor is done in reference to the base. We can use this fact to locate the base. For example choose two transistor leads at random and measure the resistance between them. If, after reversing the polarity of the test leads, either position yields a reading of infinity, you have located the collector and the emitter. The remaining lead, logically enough, is the base. Another method of locating the base is to observe the direction of current flow, which goes from the base to the emitter and the collector. (see Fig. 9 and 10)

**2. The Collector and Emitter**

After finding the base with either of the techniques just described, change the measurement range to x1K. Connect the test leads to the two unidentified transistor leads. Keep the base from contacting either of the leads and shorting out. Hold the base and one lead against one finger and take a measurement. If the pointer swings widely, the lead held by your finger is the collector and the remaining lead is the emitter. If the pointer does not swing, by either reversing the polarity of the leads or holding the other transistor lead the meter will register deflection. (Photo 9) The reason for this is that NPN and PNP transistors require the opposite polarities to achieve the same result in this test.

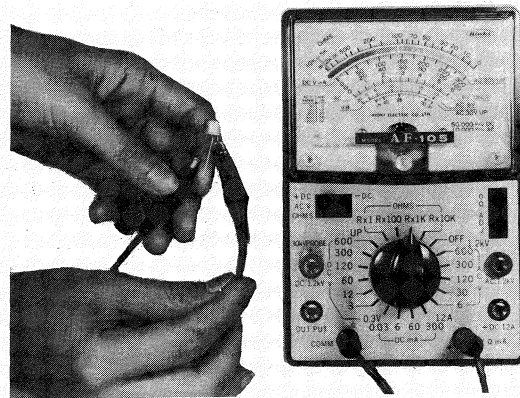

Photo 8 Finding the collector and emitter

## How to Identify NPN and PNP Transistors

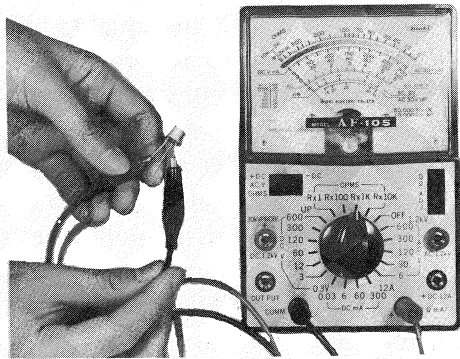

Photo 9 NPN or PNP

Prefix	Type	Classification
2SA	PNP	For radio frequencies
2SB	PNP	For audio frequencies
2SC	NPN	For radio frequencies
2SD	NPN	For audio frequencies

Table 2 Classification of Japanese PNP & NPN type transistors

All Japanese transistors are classified with a prefix as shown in Table 2. The table should make it easy to distinguish one type from the other.

American and other foreign transistors can be identified as to type by closely following the procedures previously outlined for locating the collector and emitter.

54

## 8) Variable resistors

### Quality Test

Defects in a variable resistor will often be found to be bad contacts or defective insulation.

### Bad Contact

Connect the terminals of the multimeter to the variable resistor as shown in Photo 10a. Turn the shaft gradually clockwise, and the pointer on the meter will show a smooth variation of resistance value. If the slider contact is defective, the measured resistance may suddenly jump to infinity, or the variation of resistance value will be rough and uneven (see Photo 10b). To choose a correct range for measuring ohms, consult the rated resistance of the device and set accordingly.

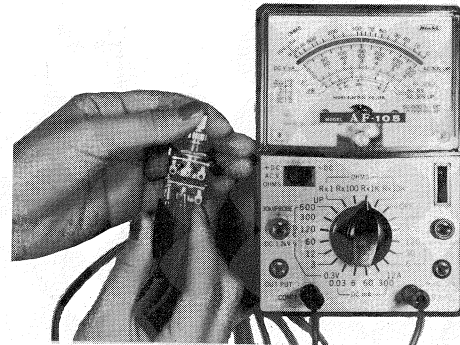

a

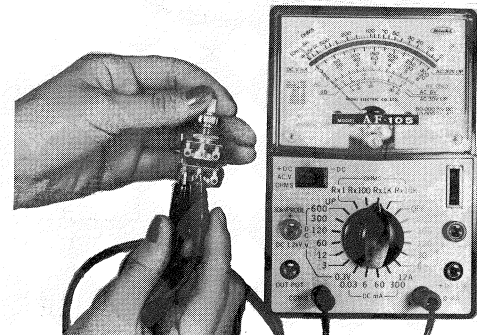

b

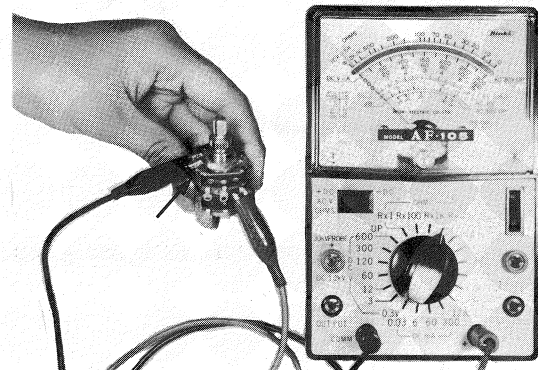

c

Photo 10 Checking of the variable resistor

### Defective Insulation

Connect the test leads as shown in Photo , and set the ohm range to the highest setting available (x1K or x10K).

Normally the resistance value should be infinitely large ( $\infty$ ) as shown in Photo 10c. If any resistance figure other than infinity is measured, the variable resistor has defective insulation.

**Precautions**

The same precautions apply here as those mentioned for resistors.

**NOTE:** Have you ever experienced what seemed to be a noisy variable resistor only to find the noise persisted after the variable resistor was replaced?

More than likely the noise is due to defective insulation in the coupling capacitor, resulting in a leakage of DC voltage across the variable resistor. Set your multimeter to a low DC Volt range and check the voltage across the variable resistor. It should be zero. If you do get a DC voltage reading, replace the coupling capacitor. In case you find this kind of noise, it is better to first check whether DC voltage is appearing at the terminals of the variable resistor. This check has to be done with the slider shaft turned fully clockwise and counter-clockwise.

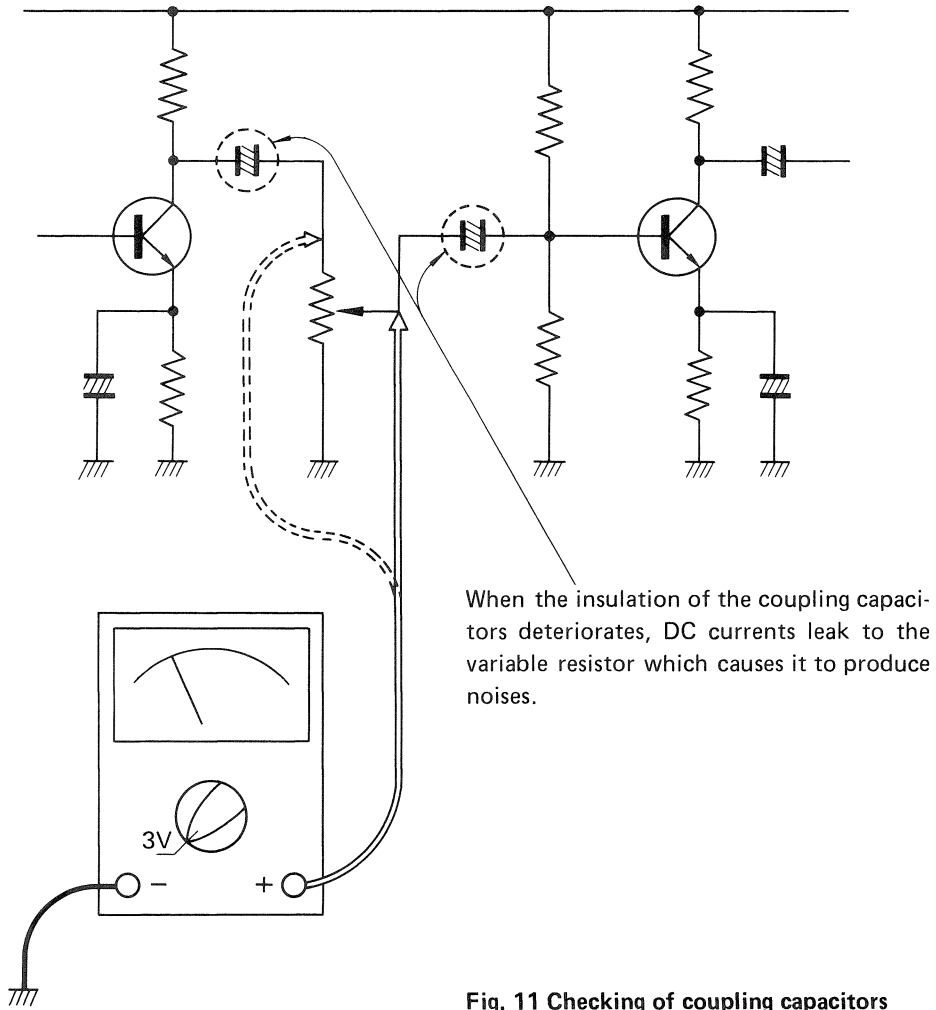

**Fig. 11 Checking of coupling capacitors**

# Electricity: Basic Theories (2)

## Ohm's Law—2

In the previous issue, the basics of Ohm's Law were discussed. Examples were given of DC current calculations with resistors connected in series, in parallel and in series-parallel. How the voltage drop across resistors is calculated was also explained.

This issue will deal with current shunting in parallel circuits as well as some concrete applications in everyday servicing.

### 5. Current Shunt in Parallel Circuits

When two resistors,  $R_1$  and  $R_2$ , are connected in parallel, and a voltage  $V$  is supplied across their ends, the following current distribution takes place. Current  $I$  flows through the circuit, and the current in resistors  $R_1$  and  $R_2$  is  $I_1$  and  $I_2$ , respectively. In Fig. 14, the current distribution in a circuit with two resistors connected in parallel is shown.

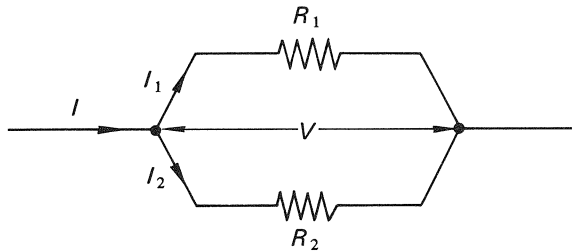

Fig. 14 Current distribution in a circuit with two resistors connected in parallel

From this, the following formula is obtained:

$$R_1 I_1 = R_2 I_2 = V$$

therefore,  $\frac{I_1}{I_2} = \frac{R_2}{R_1}$

Since the current shunt in a resistor is inversely proportional to the resistance value of the resistor, it can be equated as follows:

$$I = I_1 + I_2$$

therefore,  $I_1 = I - I_2$  and  $I_2 = I - I_1$ .

Then,  $R_1 I_1 = R_2 (I - I_1)$ ,  $R_1 I_1 = R_2 I - R_2 I_1$ .

Expressed in the opposite way, the term  $R_2 I_1$  becomes,  $R_2 I = R_1 I_1 + R_2 I_1 = I_1 (R_1 + R_2)$

therefore,  $I_1 = \frac{R_2}{R_1 + R_2} \times I$  ..... (1)

Similarly,  $I_2 = \frac{R_1}{R_1 + R_2} \times I$  ..... (2)

In short, when two resistors are connected in parallel, a large current flows through the lower resistor and a small current flows through the higher re-

sistor. The absolute amount of current in the resistors can be obtained from equations (1) and (2).

When three resistors are connected in parallel, these equations, however, cannot be applied. In this case, the composite resistance value must first be obtained and the voltage across them determined. Then, the current flow in the individual resistors can be calculated. This is the orthodox method and the quickest way of obtaining the result.

The composite resistance  $R$  for three resistors connected in parallel is given as:

$$R = \frac{R_1 R_2 R_3}{R_1 R_2 + R_2 R_3 + R_3 R_1}$$

The voltage  $V$  across the resistors is obtained by multiplying the resistance  $R$  by the current  $I$ . Then, the current flow through the individual resistors can be calculated as follows:

$$I_1 = \frac{V}{R_1}, I_2 = \frac{V}{R_2} \text{ and } I_3 = \frac{V}{R_3}$$

Fig. 15 shows the current distribution in a circuit with three resistors connected in parallel.

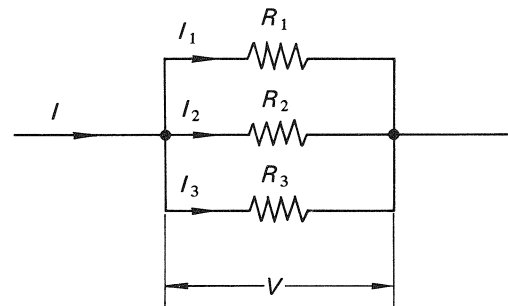

Fig. 15 Current distribution in a circuit with three resistors connected in parallel

### 6. Extended Application of Ohm's Law

The previous calculations given for determining the voltage/current distribution in circuits with resistors connected in series or in parallel are based on DC voltage sources. However, the same calculations can also be applied to AC circuits as well.

In the case of AC circuits, too, the calculations are also based on Ohm's Law. However, the theory of AC circuits will be dealt with in a later issue.

#### 1) Connecting a number of speakers

A common request from many customers is to have a number of speakers connected to the same channel of their stereo power amplifiers.

Normally, transistorized power amplifiers are designed to drive a load (speaker) of more than 4 ohms. If, however, the load impedance\* is less than 4 ohms, an overload (excessive collector current) will result, and breakdown and/or unstable operation may be induced. It is very important, therefore,

that the composite impedance of the speakers be held higher than 4 ohms when attempting to connect a number of speakers to the same output terminal.

\* Impedance corresponds to resistance in DC circuits (used in AC circuits). The unit is the  $\Omega$ .

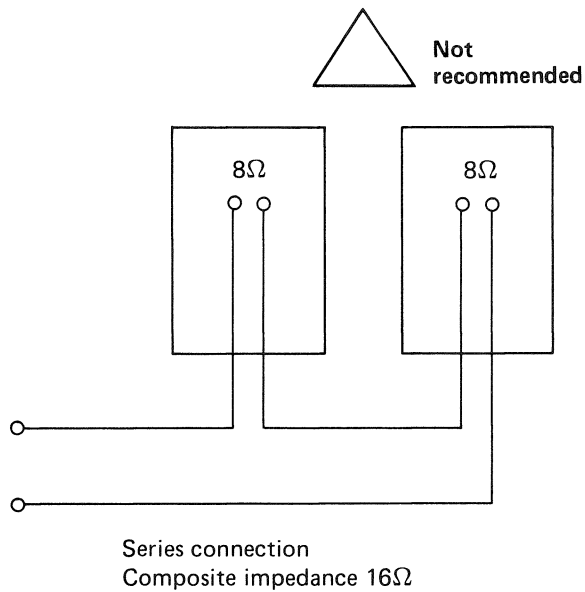
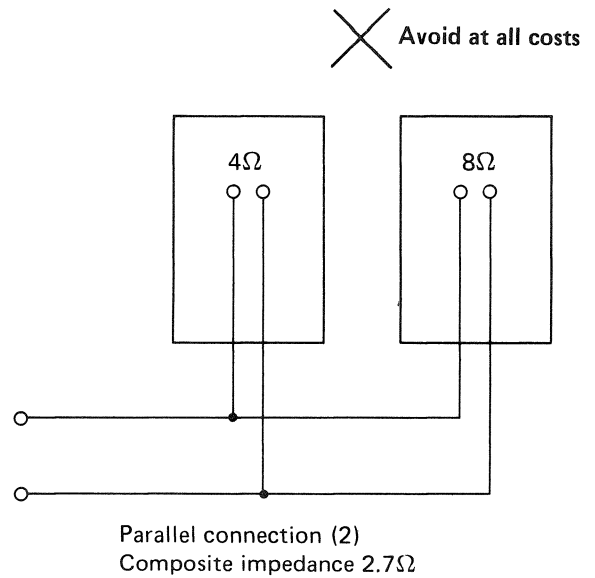
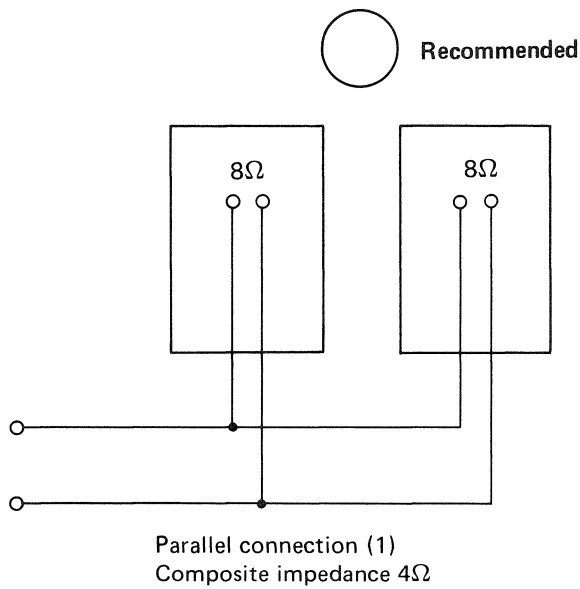

Note: When two speakers are connected in series, the impedance is the sum of both speakers. The maximum power output available is also reduced. When two different types of speakers are connected in series, the characteristics of each speaker affect one another. This degrades the overall quality of the system and is not recommended.

Fig. 16 Connection of two speakers

Connections using three or more speakers are shown in Fig. 17 for reference only.

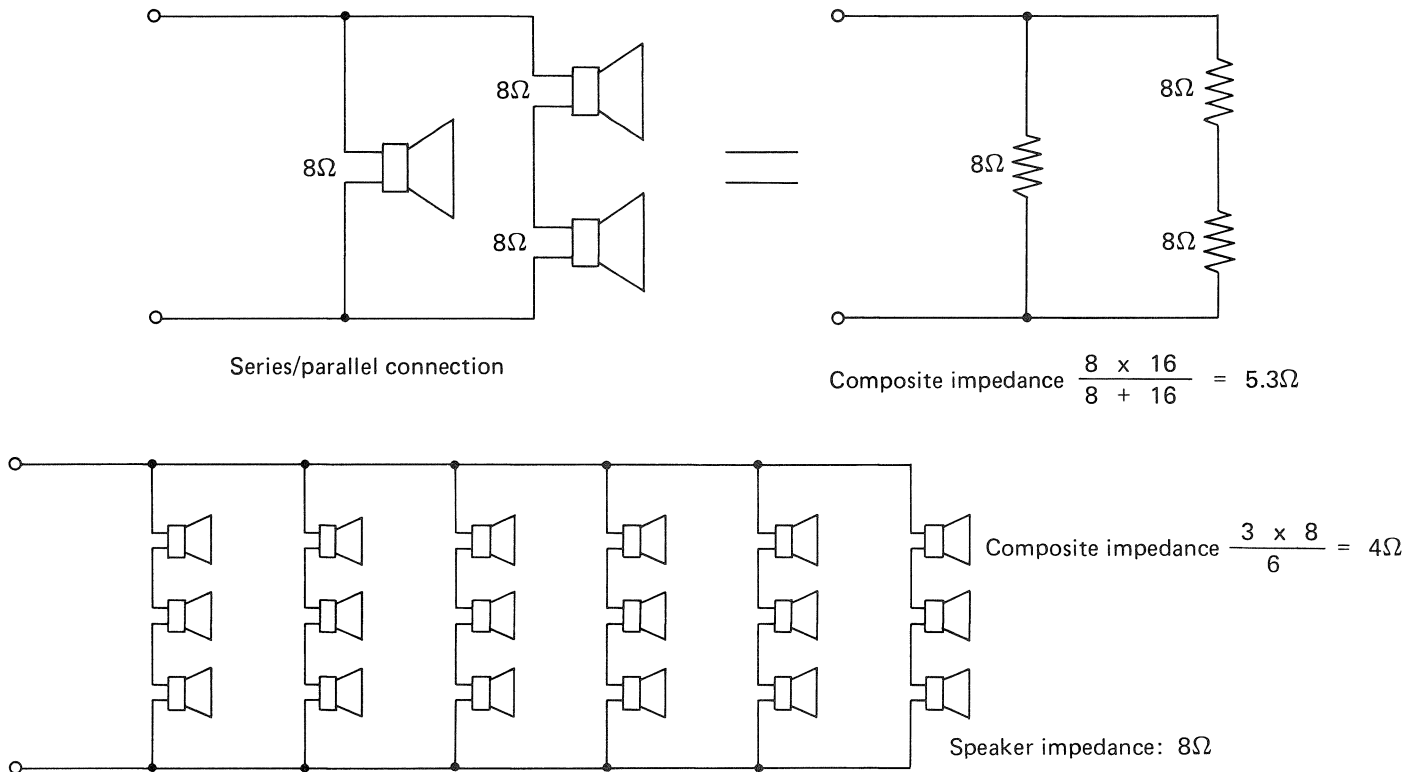

Fig. 17 Connection of three or more speakers

58

## 2) Extension of voltmeter measuring range

When measuring voltages with a voltmeter, it is impossible to measure anything higher than the maximum range of the instrument. However, the measurement voltage can be increased by connecting a resistor in series to the meter as shown in Fig. 18.

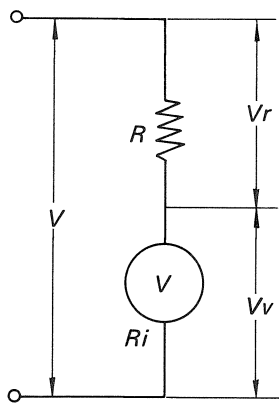

Fig. 18 Increased measuring voltage

In Fig. 18,  $V_v$  represents the full voltage measuring scale of the voltmeter.

$$\text{If } V_v = \frac{R_i}{R + R_i} \times V$$

$$\text{Then, } V_v (R + R_i) = VR_i$$

$$\text{Therefore, } V = \frac{R + R_i}{R_i} \times V_v$$

The measured voltage can be obtained by multiplying the meter reading, 600V in the 1kV range, for example, by the  $\frac{R + R_i}{R_i}$  factor. This factor will be 2 if the external resistance  $R$  equals the internal resistance of the voltmeter  $R_i$ , that is,  $\frac{R + R_i}{R_i} = 2$ , then, the 600V meter reading will be doubled to 1.2kV.

Similarly, it is possible to extend the voltage measurement range of a voltmeter 10 times by connecting an external resistance  $R$  which has the following relationship:

$$\frac{R + R_i}{R_i} = 10$$

$$\text{Then, } R + R_i = 10R_i$$

$$\text{Therefore, } R = 9R_i$$

If the internal resistance of the voltmeter is  $1M\Omega$  at 1kV, then a  $9M\Omega$  resistor must be connected in series to the meter. This will then extend the voltage range from 1kV to 10kV and calculations can be made accordingly. Note that the multiplier should be more than 1.



### 3) Extending DC current range

When measuring current with an ammeter, it is impossible to measure currents larger than the maximum range of the instrument. However, the range can be extended by connecting a resistor in parallel to the ammeter as shown in Fig. 19.

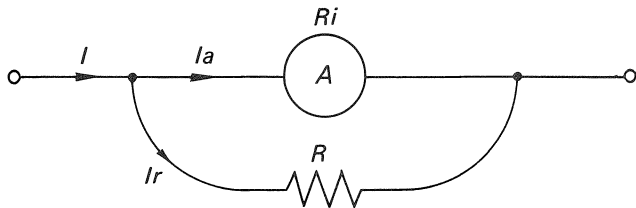

$R_i$ : Internal resistance of the ammeter

Fig. 19 Extension of measuring current

$R_i$ : Internal resistance of the ammeter

In Fig. 19, if  $R_i$  represents the full scale value, then the equation will be as follows:

$$I_a = \frac{R}{R + R_i} \times I, IR = I_a (R + R_i)$$

therefore,  $I = \frac{R + R_i}{R} \times I_a$

This means that the meter reading must be multiplied by the factor  $\frac{R + R_i}{R}$ . To extend the ammeter 10 times, a shunt resistor having a  $\frac{R + R_i}{R} = 10$  relationship must be connected to it.

$$10R = R + R_i, \text{ then } 9R = R_i$$

therefore,  $R = \frac{1}{9} R_i$

In other words, a low value resistor having 1/9 of the internal resistance of the ammeter must be connected in parallel to extend the ammeter range 10 times. Calculations with any number of multiples can be obtained accordingly. The multiplier, however, must always be more than 1.

### 4) Voltage/current distribution in electronic circuits

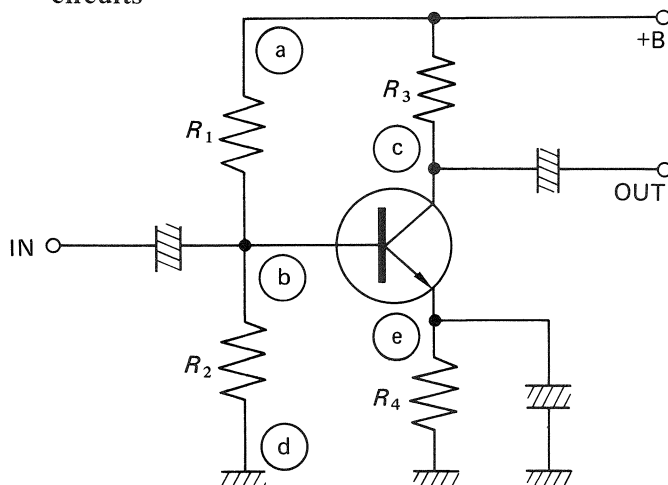

Fig. 20 One-stage transistorized amplifier circuit

A typical application of Ohm's Law can be found in an electronic circuit. And a one-stage transistorized amplifier circuit like the one shown in Fig. 20 is a typical example.

In this circuit, the bias or base voltage is determined by the voltage dividers  $R_1$  and  $R_2$ . By letting the base potential be  $V_b$ , it can be equated as follows:

$$V_b \cong \frac{R_2}{R_1 + R_2} \times +B$$

(Strictly speaking, the base current flow through  $R_1$  should also be considered, but since it is negligible, the above equation can be applied)

By letting the collector current be  $I_c$ , the collector voltage  $V_c$  is expressed as:

$$V_c = +B - (R_3 \times I_c)$$

If  $I_c$  is unknown, then measure  $V_c$  and calculate as follows:

$$I_c = \frac{+B - V_c}{R_3}$$

Then, by letting the emitter voltage be  $V_e$ , the emitter current  $I_e$  is given as:

$$I_e = \frac{V_e}{R_4}$$

Since the emitter current is the sum of the collector and base currents, the following equation is used:

$$I_B = I_e - I_c$$

The collector current of a transistor varies in response to changes in the base current. That is, the collector current is controlled by the base current. When the base voltage varies, the collector voltage varies accordingly due to the voltage drop across the collector resistor. The AC voltage, which is proportional to the variation in the base potential input, can be obtained when the varied collector voltage is taken out.

From this it can be easily seen that an amplifier circuit, no matter how complex, provides a typical application for Ohm's Law and demonstrates how the unique characteristics of transistors are applied. Armed with this knowledge and a thorough understanding of transistors, it is possible for anyone to design a transistorized amplifier. In the forthcoming issues, the theory of AC circuits will be covered in greater depth.

# First Step in Audio (1)

## Specifications—1

**SX-1250 SPECIFICATIONS**  
**POWER AMPLIFIER SECTION**  
**Continuous Power Output is 160 watts\* per channel, min. RMS at 8 ohms or 200 watts\* per channel at 4 ohms from 20 Hertz to 20,000 Hertz with no more than 0.1% total harmonic distortion.**

Total Harmonic Distortion: (20 Hertz to 20,000 Hertz, from AUX)	No more than 0.1% (continuous rated power output)	Filter: LOW: HIGH: Loudness Contour: (volume control set at -40dB position)	30Hz (12dB/oct.) 8 kHz (12dB/oct.) +6dB (100Hz), +3dB (10
Intermodulation Distortion: (50 Hertz: 7,000 Hertz=4: 1, from AUX)	No more than 0.05% (80 watts per channel power output, 8 ohms)	Hum & Noise (IHF, short circuited A network, rated power)	75dB 90dB -20dB
	No more than 0.07% (1 watt per channel power output, 8 ohms)	PHONO: AUX, TAPE PLAY:	
	No more than 0.1% (continuous rated power output)	Muting: <b>FM TUNER SECTION</b>	Mono: 8.7dBf (1.5μV), Stereo: 14.5dBf (2.9μV)
	No more than 0.05% (80 watts per channel power output, 8 ohms)	Usable Sensitivity:	Mono: 11.5dBf (2.1μV) Stereo: 36.0dBf (35μV)
	No more than 0.07% (1 watt per channel power output, 8 ohms)	50dB Quieting Sensitivity:	Mono: 80dB, Stereo: 74dB
		Signal-to-Noise Ratio (at 65dBf):	
		Distortion (at 65dBf)	0.1% (mono), 0.25% 0.1% (mono), 0.2% 0.3% (mono), 0.3% 30Hz to 15,000Hz +
		100Hz:	
		1 kHz:	
		6 kHz:	
		Frequency Response:	1.0dB 83dB
		Ratio:	

### How to Read the Ratings

A look through any catalog should convince you that every product has many ratings and specifications. They are necessary, of course, to evaluate the performance in some quantitative way and to facilitate the comparison of different models. But specifications can't work for you in the way they were intended unless you know how to read them properly. A course on interpreting audio specifications will follow in upcoming issues. In this issue we will start with a discussion of Audio Frequency ratings and specs.

### 1. Power Amplifier Section

#### 1) Rated Power Output

This is defined as the maximum power that can be obtained continuously without exceeding the rated distortion figure. This term is also called 'Continuous Power Output' or 'Effective Power Output.' In

addition to meeting a distortion specification, rated power must also be considered within the context of its frequency bandwidth. The bandwidth specified is of 1kHz or between 20Hz to 20kHz. The amplifier load is always specified as a pure resistive (non-inductive) load of either 8 ohms or 4 ohms. There are two ways that an amplifier can be driven to obtain rated power specs: one channel driven or both channels driven. For four-channel amplifiers, the option of all four channels driven is included. As the name implies, the number of driven channels is the number of channels to which a signal is applied during the test. For a stereo amplifier, the more stringent test and the more helpful specification is the one for both channels driven.

All Pioneer amplifiers and receivers are rated with both channels driven.

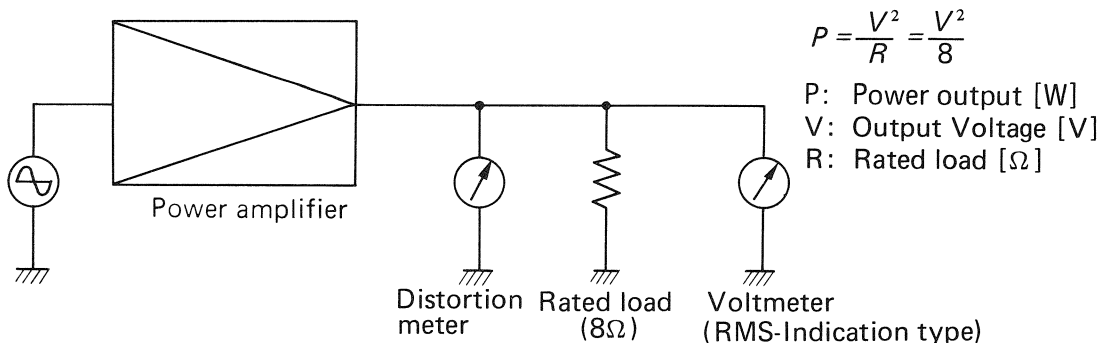

Fig. 1 Power output measurement

## 2) Total Harmonic Distortion (THD)

Signals having the frequency of an integer multiple to the fundamental signal are called harmonics.

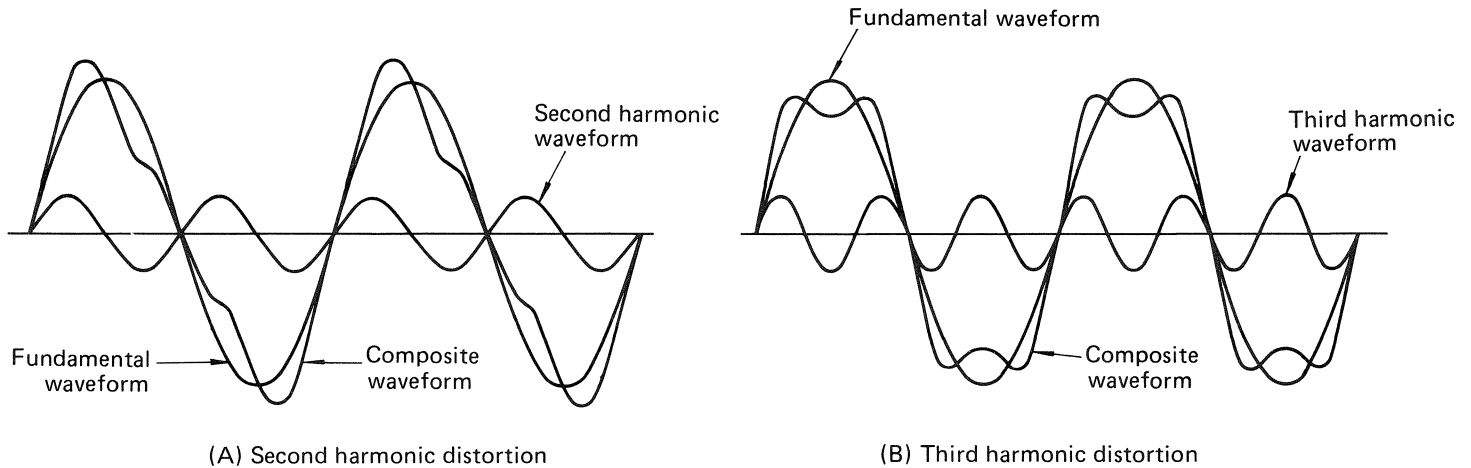

Fig. 2 Harmonic distortion

Harmonic distortion is a typical non-linear distortion, and is measured by applying a sine wave signal of a known strength and then comparing it to the strength of all harmonic signals generated in the amplifier. Total Harmonic Distortion is normally represented by a percentage (%) which is obtained from the equation on the right:

$$D = \frac{\sqrt{A_2^2 + A_3^2 + \dots + A_n^2}}{A_1} \times 100 (\%)$$

$D$  : Total harmonic distortion

$A_1$  : Fundamental signal amplitude (RMS)

$A_2$  : Second harmonic signal amplitude (RMS)

$A_3$  : Third harmonic signal amplitude (RMS)

$A_n$  : nth harmonic signal amplitude (RMS)

( $n = 1, 2, 3, \dots$ )

## 3) Intermodulation Distortion (IMD)

When feeding a signal containing plural frequencies to a circuit or amplifier possessing a certain amount of non-linearity, the output will be composed of a broad spectrum made up of sum and difference frequencies resulting from the original input frequencies.

This undesired frequency spectrum is called intermodulation distortion. Since the frequency components of intermodulation distortion bear no integer relationship to the original input frequencies, inter-

modulation distortion severely degrades the sound quality.

The method of measuring intermodulation distortion is done by applying two signals of 50Hz and 7000Hz, 4:1 in amplitude, to an amplifier. This is known as the SMPTE. (Society of Motion Picture and Television Engineers). (see Fig. 4)

Intermodulation distortion of an amplifier is obtained by measuring to what extent the high frequency signal is modulated by the low frequency

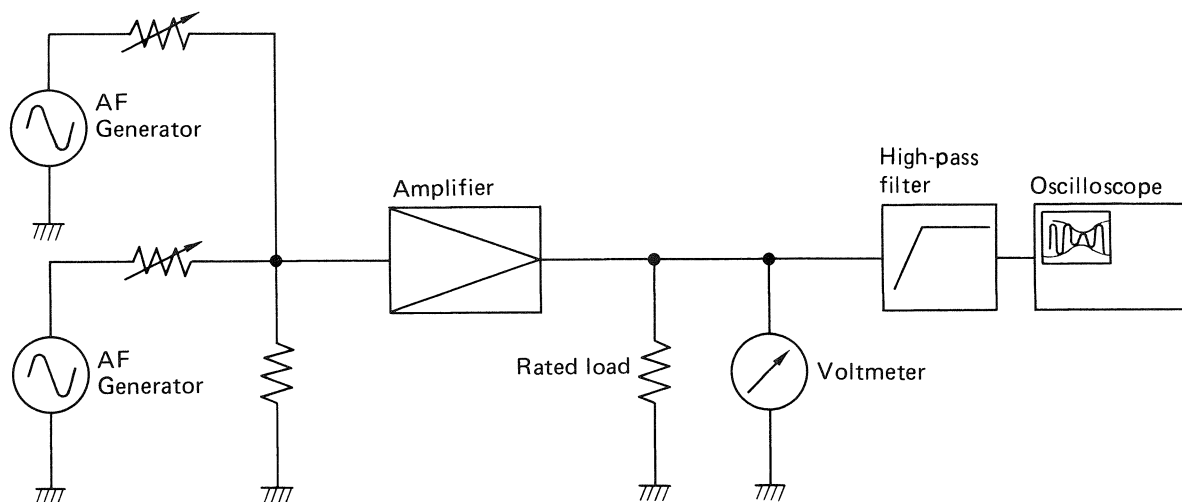

Fig. 3 Measurement of IM distortion

signal.

When measuring, the signals are applied to the amplifier as shown in Fig. 4a, and the output signal is fed to the oscilloscope through a high-pass filter. The oscilloscope shows the modulated waveform as shown in Fig. 4b.

The distortion figure is calculated by the formula below.

$$DIM = \frac{A - B}{A + B} \times 100 (\%)$$

In practice, the above-mentioned method cannot be very accurate, especially when the distortion value

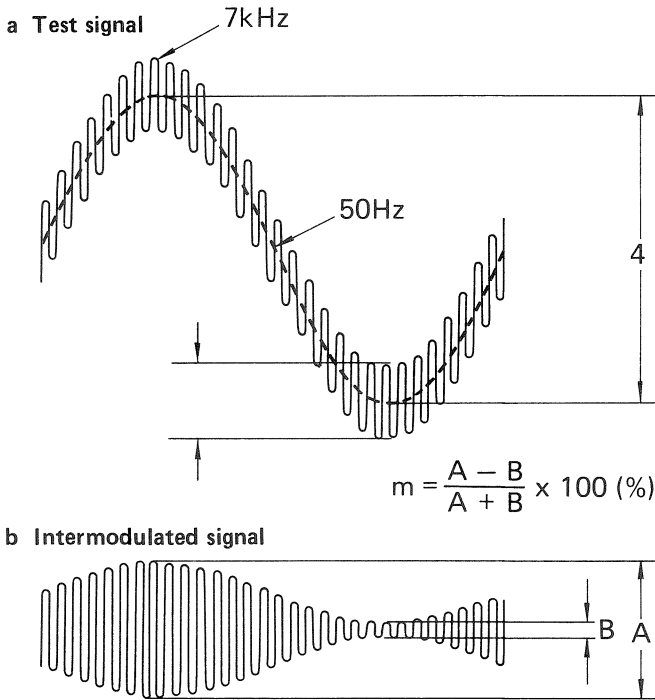

Fig. 4 Measurement of IM distortion

is small.

Therefore, a ready-made SMPTE-specified IMD meter is used instead.

#### 4) Damping Factor (DF)

Damping Factor is an indirect representation of power amplifier output impedance. We can derive damping factor by the equation  $DF = \frac{Z_L}{Z_0}$  where  $Z_0$  is the amplifier's output impedance, and  $Z_L$  is the impedance of the speaker.

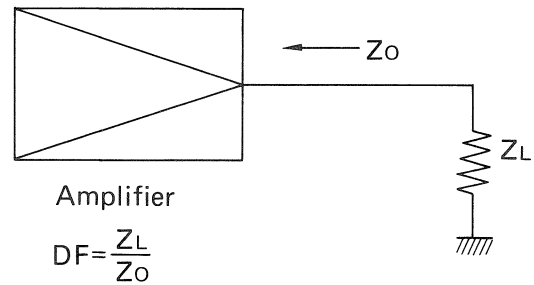

Fig. 5 Definition of damping factor

Low frequency reproduction is not only influenced by the speaker (woofer), the enclosure and the listening room acoustics, but also the output impedance of the amplifier.

If the damping factor is low, which is to say the amplifier's output impedance is high, there is less precision in the reproduction of low frequency tones (Fig. 6). An explanation for this is that low DF causes poor damping of transient vibration in the woofer cone. If the DF is sufficiently high, most of the transient vibration can be damped.

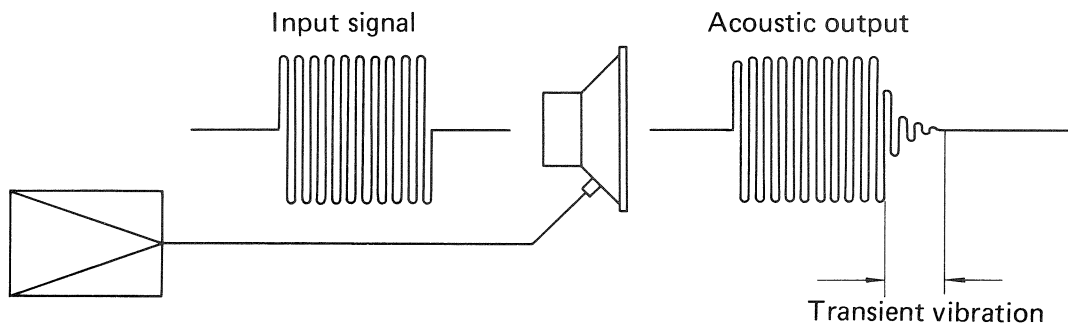

Fig. 6 Transient response of speaker

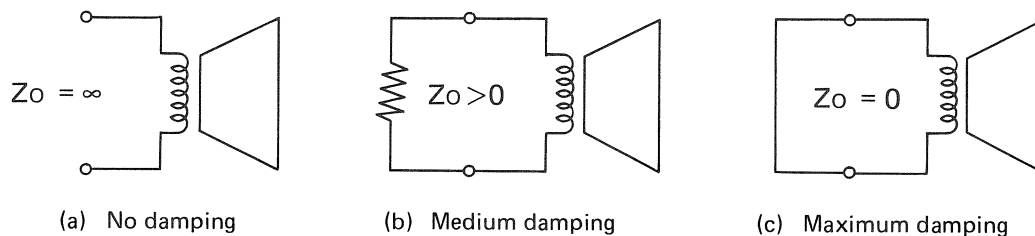

Fig. 7 Electrical damping to speaker

When a tone burst signal (a tone which is stopped sharply) is applied to a speaker, the cone will not immediately stop vibrating at the end of the signal, as shown in Fig. 6. The extent of the extra vibration in the cone depends largely on the power amplifier output impedance and on the performance of the speaker.

During transient vibration, the voice coil acts as a generator set up by the movement in the magnetic fields. The lower the output impedance, the higher the damping factor, and the more electro-magnetic braking is applied to the speaker cone (Fig. 7).

Output impedance is measured by the Open-Load Method, meaning that the impedance is measured both with load and then without load. As shown in

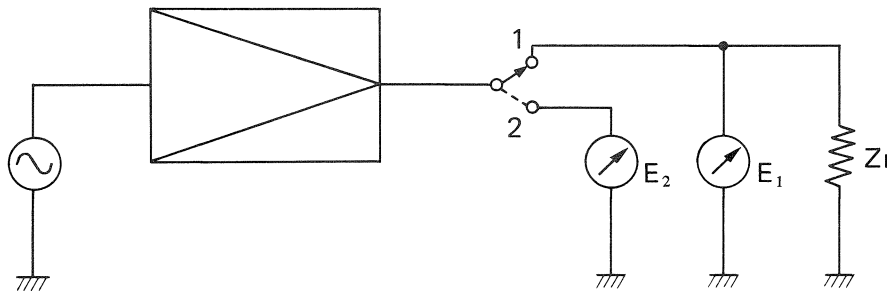

Fig. 8 Measurement of damping factor

### 5) Frequency Response

The frequency response of an amplifier is defined as the output amplitude response for a range of input frequencies of standard amplitude. It may also be expressed in terms of output dB, a measurement of amplitude, under standard test conditions.

In measuring frequency response, the input frequency may vary, but the amplitude remains constant, and variations in output amplitude are recorded in dB.

In general, the input signal is adjusted so that a reference output level is obtained at 1kHz. This reference level is defined as 0dB, and all other output frequencies are measured in terms of + or - dB level. The usual output level is 1W. A representation of the frequency response of an amplifier might be given as 5Hz to 100kHz, +0dB, -1dB.

### 6) Signal-to-Noise Ratio (S/N ratio)

Signal-to-noise ratio can be defined as the ratio between the desired signal output and undesired noise output. It is measured in dB.

In general, the S/N ratio of an amplifier is a straight calculation as defined above, but the more common method for high-fidelity products is the so-called IHF weighted system, where a filtering network is employed to tailor the measurement to the sensitivity of the human ear. The noise component so filtered is then compared to the rated power and the

Fig. 8, a switch controls measurement by voltmeters of both  $E_1$ , the voltage with load, and  $E_2$ , the voltage without load. The output impedance is then calculated using the following equation:

$$Z = \frac{E_2 - E_1}{E_1} \times Z_L$$

Normally, the load used ( $Z_L$ ) is an  $8\Omega$  resistor.

Since the damping factor is defined as  $\frac{Z_L}{Z_0}$ , the equation will be:

$$DF = \frac{Z_L}{Z_0} = \frac{Z_L}{\frac{(E_2 - E_1) \times Z_L}{E_1}} = \frac{E_1}{E_2 - E_1}$$

result recorded as the number of dB below the output power. Fig. 9 shows the noise level measurement set-up.

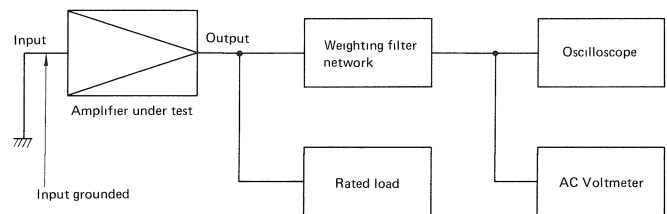

Fig. 9 Noise level measurement

With the maximum power output as  $P_0 \text{ max.}$  and the voltage level at maximum power represented by  $E_0 \text{ max.}$ ,

$$P_0 \text{ max.} = \frac{(E_0 \text{ max.})^2}{Z_L}$$

Therefore:

$$E_0 \text{ max.} = \sqrt{P_0 \text{ max.} \cdot Z_L}$$

$$S/N = 20 \log \frac{\sqrt{P_0 \text{ max.} \cdot Z_L}}{E_n} \text{ (dB)}$$

$E_n$ : Noise level

IHF (Institute of High-Fidelity Manufacturers Inc.) The IHF test standard was established to unify test methods for hi-fi equipment, and is widely used in Japan and Europe, as well as in the U.S.

The IHF short-circuit network A, shown in Fig.10, is the filtering circuit used to weight the noise in approximation of its audibility by human ears.

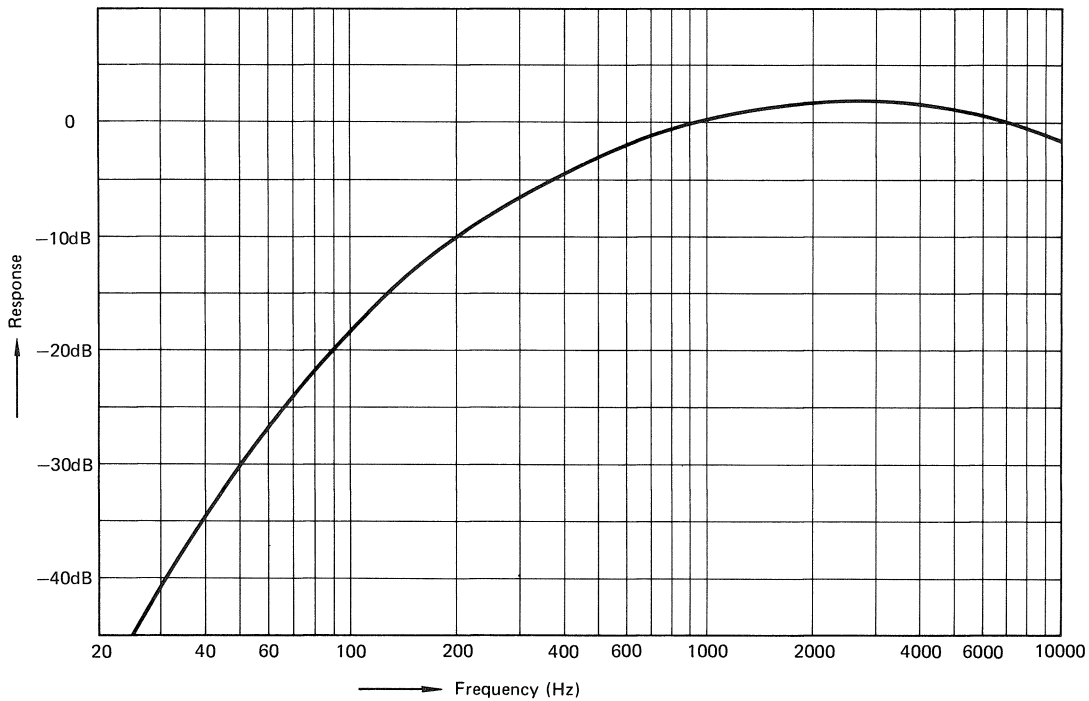

Fig.10 Frequency characteristics of the IHF short-circuited A network.

64

### 7) Power Bandwidth

It was common at one time to measure the maximum output power of an amplifier at a medium frequency (1kHz), but although this served as a rough guide to amplifier power, it in no way assured that the amplifier was capable of producing this same high power over a broad range of frequencies. For example, at low frequencies, a deterioration of the power supply block's smoothing efficiency can restrict the power output. And in the high frequency range, the decrease of  $h_{fe}$  of the transistors can also lower the output.

The power bandwidth, then, is a specification which gives the range of frequencies within which the maximum output power never falls below 50% (3dB down) of the output power at 1kHz: If an amplifier puts out 100W (at 0.1% distortion) at 1kHz, and the power drops off to 50W (at 0.1% distortion) at 2Hz and 80kHz respectively, the power bandwidth is specified as 2 to 80kHz (again at 0.1% distortion).

That power bandwidth is an indication of the frequency range in practical use.

An example of power bandwidth is given in Fig. 11.

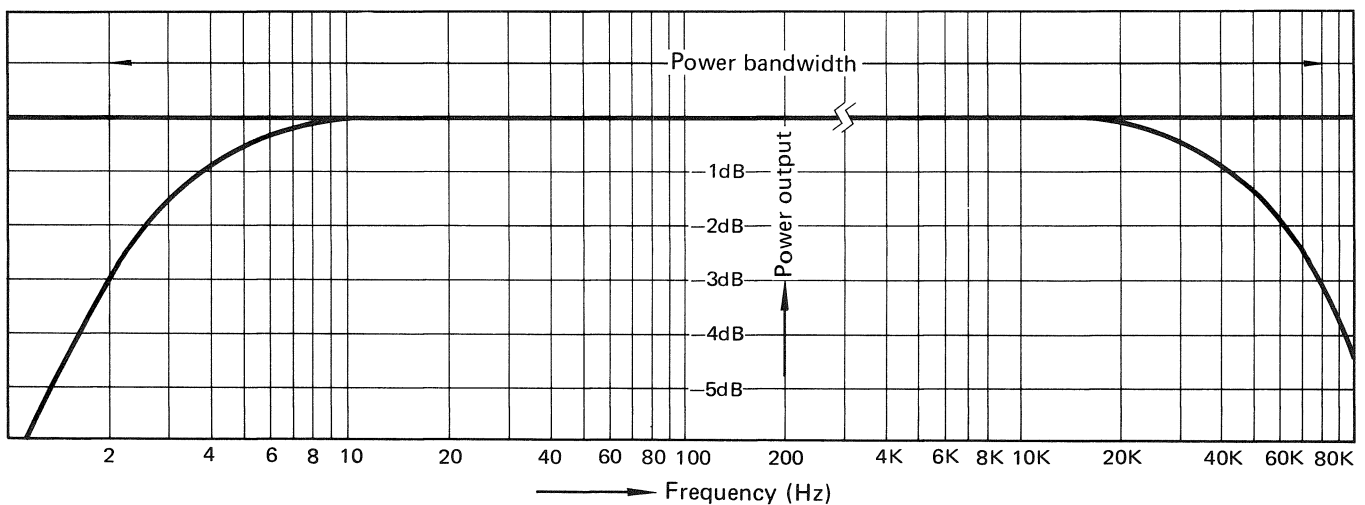

Fig. 11 Power bandwidth

## 8) Input Sensitivity/Impedance

Although these figures are not performance figures strictly speaking, they do offer important data on the compatibility of a given amplifier with associated equipment, such as preamps, graphic equalizers, and dynamic processors. For example, the figure 1V/50K $\Omega$  specifies that the power amplifier requires 1V of input power to produce its rated output, and it also specifies that the input impedance is 50K $\Omega$ .

## 2. Preamplifier Section

### 1) Input Sensitivity/Impedance

A preamplifier has a variety of input terminals, such as PHONO, MIC, TUNER, AUX, TAPE. The input sensitivity figure for each of these inputs gives the required input voltage level to produce the rated output. The input impedance figure describes the compatibility of the input with appropriate transducers. The choice of a low impedance microphone (600 $\Omega$ ) or high impedance (50K $\Omega$ ) mic. is an example of where the input impedance would be a

critical factor.

The equalizer incorporated in the PHONO section of a preamp has frequency characteristics that are specified by RIAA standard. The frequency response through such an equalizer is not linear, meaning that some frequencies are emphasized and de-emphasized more than others.

So, in this case the input sensitivity rating only refers to the sensitivity at 1kHz. This RIAA Playback Standard curve is shown in Fig. 12.

### RIAA Playback Standard

Standard specified by RIAA (Record Industries Association of America) concerning playback characteristics of records.

Recording characteristics are also specified by RIAA (RIAA Recording Standard), and are exactly inverse to those of RIAA Playback Standard. RIAA Recording/Playback Standard is employed for all records in the world.

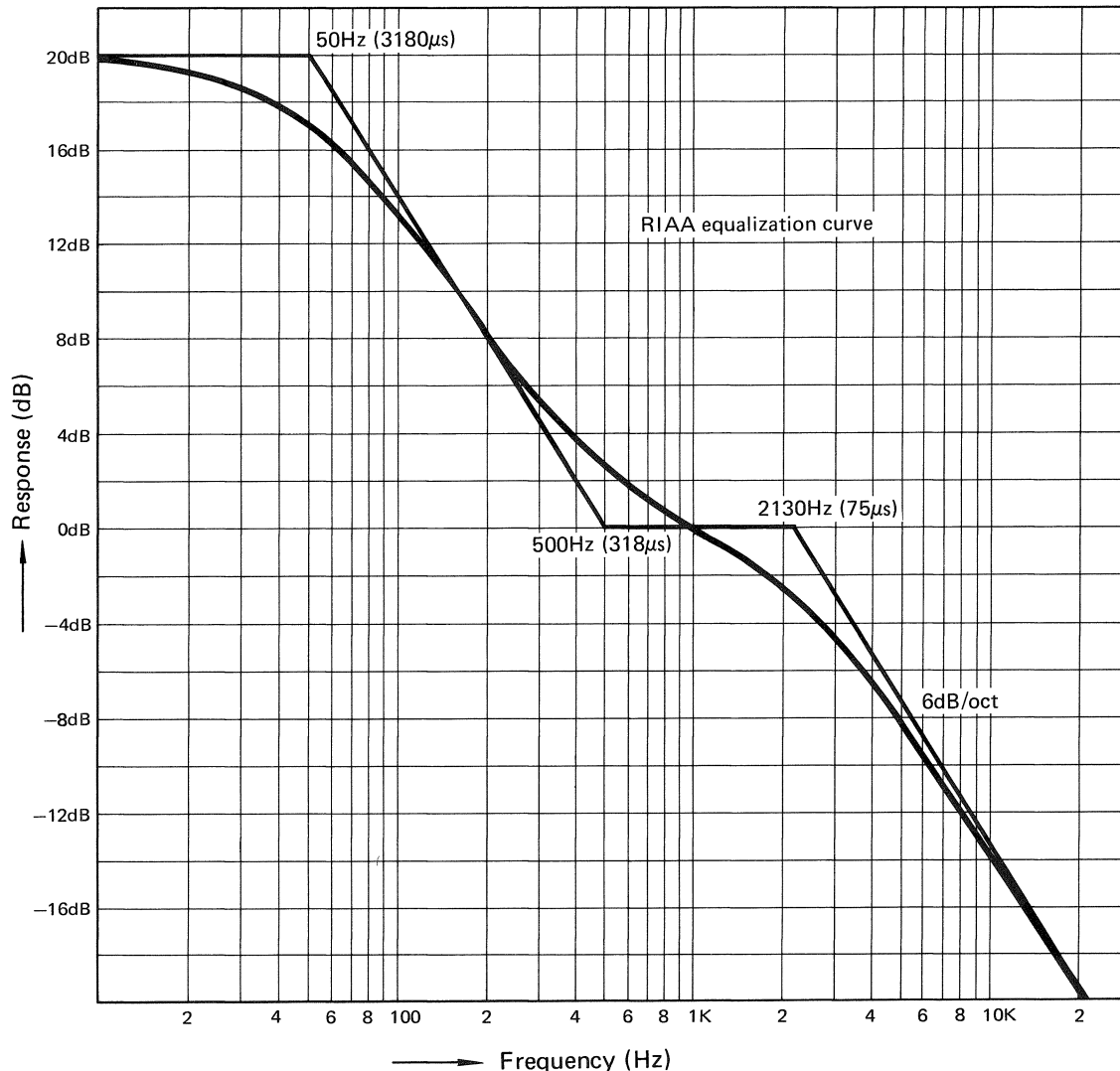

Fig. 12 RIAA playback equalization characteristics

## 2) PHONO Overload Level

The maximum input voltage that a preamp can accept at the PHONO input terminals without exceeding rated distortion at REC OUT is called its Overload Level. This parameter is especially important because the phono equalizer almost never has an input level control, meaning that any distortion that

is induced here because of excessive level can not be remedied further down the line. So in addition to wide frequency response and low distortion, preamplifiers must have a high PHONO overload level, preferably 50mV in an average-price model and 100mV in a premium quality unit at 1kHz.

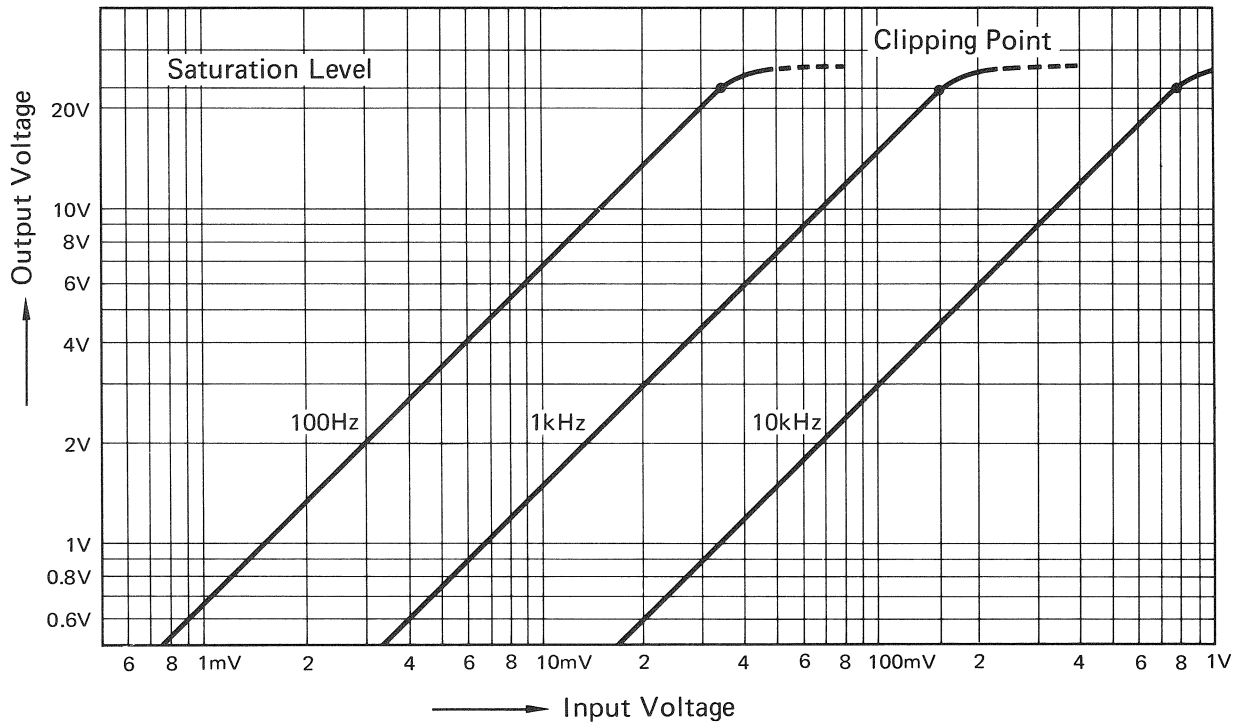

Fig. 13 PHONO overload level and saturation level

## 3) Output Level/Impedance

A preamplifier has two outputs, the REC OUT and the PRE OUT. Each of these has a rated output level and output impedance. When speaking about power amplifiers, we measure the output in terms of power (Watts), but we measure the output of preamps in volts. The voltage figure is not so much a performance figure as it is a guide to determining its suitability for use with other devices.

## 4) Total Harmonic Distortion

The definition and significance in preamps is the same as for power amps, discussed earlier.

## 5) Frequency Response

Again, the same as for power amps.

## 6) Tone Control Characteristics

The specification here is a dB measure of the boosting or attenuating of low (BASS 100Hz) or high (TREBLE 10kHz) frequencies in reference to the 0dB level of 1kHz. In the case of twin tone controls, the MAIN control effect is measured when the sub control is set to the flat position and the SUB con-

trol's effect is measured when the MAIN control is in the flat position. The SUB control value normally represents the response at frequencies of 50Hz and 20kHz.

## 7) Filter Characteristics

The figures given here, for example, 30Hz (12dB/oct) or 8kHz (12dB/oct), describe the action of filters in rolling off high and low frequency information which may be undesired, such as hiss and rumble. The first figure describes the frequency at which the signal decreases 3dB, and the second figure in parentheses describes the attenuation characteristics.

**Note:** The interval between two sounds (or signals) having the frequency ratio of 2:1 is called 1 octave. For instance, the frequency 1 octave above 1000Hz is 2000Hz, while 1 octave below is 500Hz. Similarly, the frequency 2 octaves above 1000Hz is 4000Hz, while 2 octaves below is 250Hz.

## 8) Muting

This specification refers to the extent of the signal attenuation with the muting switch turned on.



---

# Quality Information System (1)

---

## *Hello QC!*

For most of our readers, this is probably the first time they've heard about Pioneer's Quality-Information System. So in this issue the basic concept of 'quality' and what it stands for will be discussed. The actual system of operation and application will be covered in the next issue.

At Pioneer, we are making every effort to improve the quality of our products. And one sure way is through the exchange of quality information. So far, quality information has been exchanged mainly with Pioneer's overseas branches. But, in the next phase, we intend to expand the operation worldwide in order to further improve the quality of aftersales service.

Service, after all, is no less important than sales.

And the public estimation of service can have a big influence on business. One of the best ways of gaining a good reputation, therefore, is to offer high quality products backed up with good service facilities.

However, since quality improvement is too much for any one department or plant to handle, the full cooperation of service engineers is also essential. This is where 'Tuning Fork' renders a valuable service. Through its pages, the basics of quality control can be introduced to the service engineer, and methods of improvement can be discussed.

Part 1, then, deals with quality and the concept of quality control. Part II will cover 'Quality-Information System and Concrete Action.'

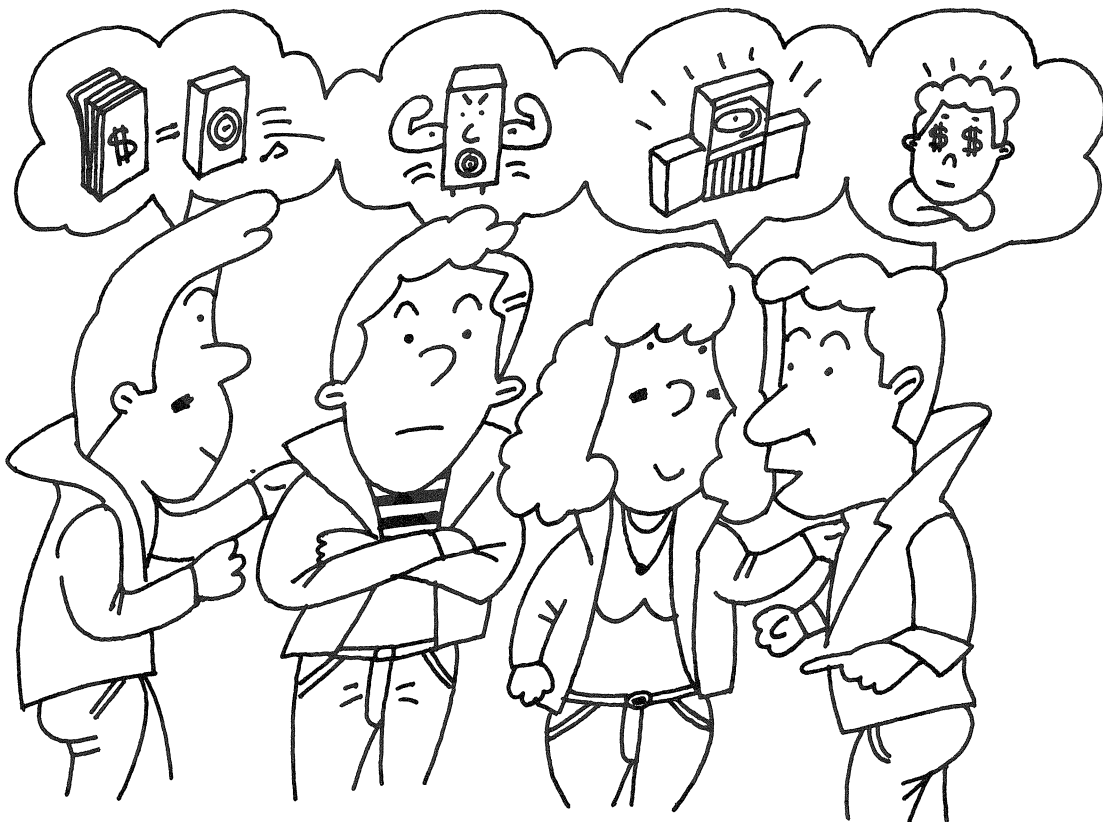

### 1. What is Quality?

"What is quality?", one might well ask. The fact is, quality means different things to different people.

A typical conversation between a group of friends on the subject of purchasing a stereo set would probably go something like this:

Jack "By the way Catherine, I hear you're going to buy a stereo set. If so, you'd better compare the specs of various models first before you buy."

Catherine "Well, as a matter of fact, the design means more to me than anything else. I must be happy with the style before I buy anything."

Heinz "But Catherine, do you realize how expensive buying a stereo can be? You must look for one that's robust and hardwearing."

Mike "That's right. But she should not forget the basic reason for wanting a stereo. Since it's for listening enjoyment, the sound is most important. Sound is everything as far as stereo equipment is concerned."

As can be seen, opinions on quality differ with individual tastes and needs. But since the term 'high-quality' appears with such regularity during the purchase or assessment of stereo systems, a better understanding of what it stands for is essential before quality control can be considered.

### Does Product Value Lie in Appearance or Contents?

Quality stands for excellence, and is derived from the latin word 'qualitas,' which means 'what it is composed of.' In addition, quality is that which is peculiar to a thing, or a characteristic or group of characteristics which distinguish one thing from another.

There are two aspects to product quality. One that can be expressed numerically as a result of meter or instrument readings. The other which cannot be measured physically, such as, design, color, tone color, touch, smell, etc. All of these are referred to as quality characteristics. Wherever possible, quality characteristics should be expressed numerically and their quantitative values given. These are called, 'quality characteristic values.'

In the case of power amplifiers, the quality characteristics refer to rated power output, output power range, intermodulation distortion, total harmonic distortion, frequency response, etc., as well as design, touch and operation of knobs, actual sound and other characteristics that are difficult to express numerically. All these together constitute the quality of the power amplifier.

### Will Every Bullet Prove Fatal?

Let's take the case of an expert shot. Most of the bullets he fires are grouped near the center of the target. The farther away from the center, the smaller the number becomes.

In the same way, 10,000 units of a particular pro-

duct are by no means identical in terms of their quality characteristics. Each one will vary to a certain degree.

From the above example it can be seen that there are numerous products which closely approximate the quality level aimed for in the planning stage, and only a few fall short of the quality target.

Now, if a distribution pattern can be determined, then the quality of the products as a group can be ascertained. Normally, a distribution pattern forms a curve in which the apex represents the quality aimed for. When the curve is gentle and the base is long, quality varies widely and the products will range from inferior to superior.

Naturally, customers always expect to buy a superior product and are very disappointed when it turns out to be inferior. Therefore, it is vitally important that the same level of quality be maintained at all times in order not to lose the customer's confidence.

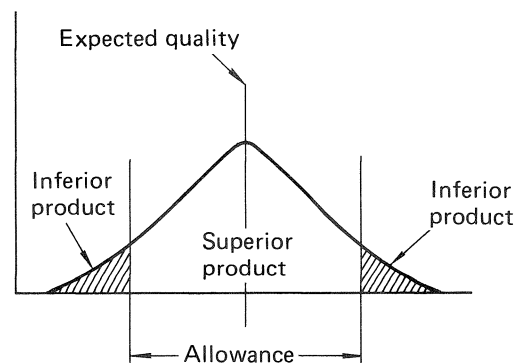
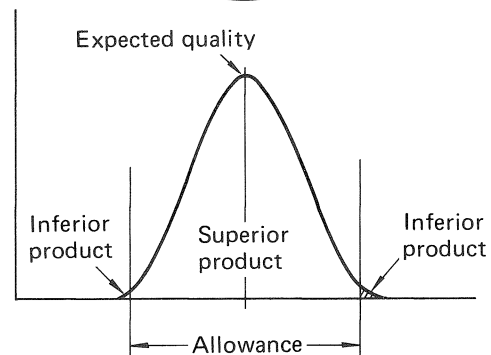
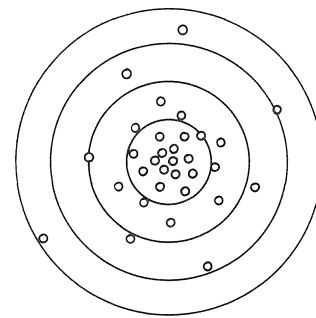

**Did the First Auto Maker Guess the Exhaust Regulations?**

Quality is not a fixed commodity. With progress, the needs of society change and people often demand stricter controls which quite often turn out to be counter-productive. The effect of imposing exhaust regulations on auto

makers is a typical example, and product suppliers must be careful not to lose sight of quality standards through organizational investigations. Moreover, quality must always be controlled so that the curve never becomes flat. This way, there will be no possibility of inferior products reaching the marketplace.



**2. What is Quality Control?**

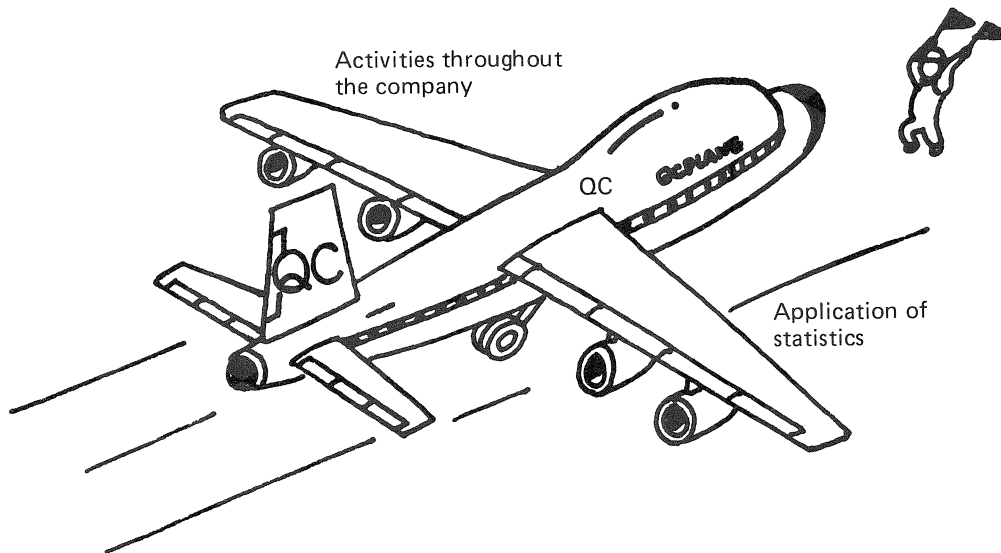

If we consider quality control to take the form of an airplane, then it cannot fly without both wings. These are represented on one side by the activities throughout the company, and on the other by the application of statistics.

Quality itself has three forms, namely:

1. The extent that customers are satisfied with the product . . . . . market quality
2. The characteristic values such as design, touch,

etc., aimed for in the planning stage . . . . . design quality

3. Variation and finish in the manufacturing stage . . . . . manufacturing quality

The control of all these factors is what QC is all about. But how is it achieved? First, let us begin by defining 'quality control.' According to the Japanese Industrial Standards (JIS), quality control is a system whereby products can be manufactured eco-

nomically to the quality standards demanded by the customers.

Modern quality control techniques adopt the statistical method which is referred to as 'statistical quality control.' This encompasses two aspects of quality control. The first covers activities throughout the company, and is used to establish an organization and official regulations which are responsible for furthering quality control activities effectively in the company. The second utilizes statistics to solve the problems encountered each step of the way.

Now let's take a look at internal quality control. In

principle, the corporate management objective is to manufacture and sell products at a profit. The business cannot succeed unless the products are sold. And the products will not sell unless they meet the quality standards demanded by the customer. So in order to realize this objective, quality control was incorporated into industrial production. Eventually all departments took up the problem of quality control and adopted the statistical method, which proved to be the most effective for manufacturing products more economically.

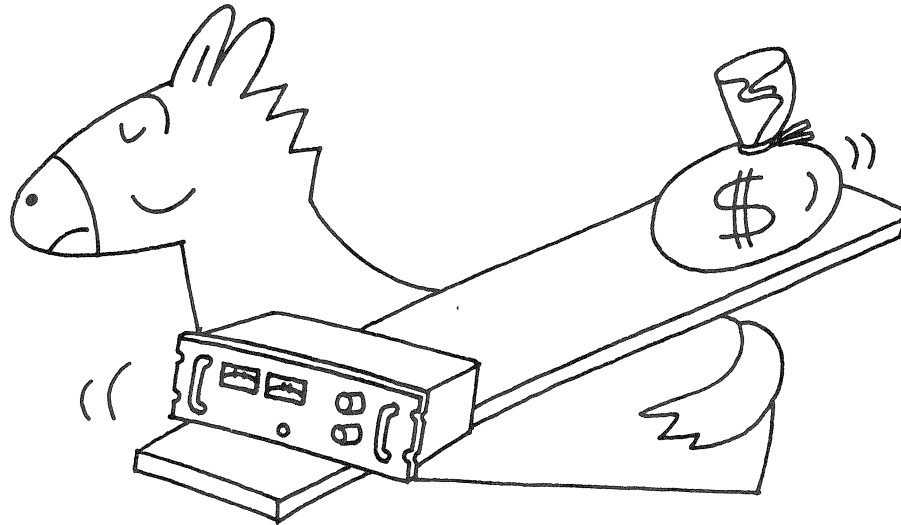

Of course, the biggest single deciding factor when buying anything is always the price. Whether a product is too expensive or too cheap depends on whether the quality characteristics such as performance, design, easy handling and aftersales service are in equilibrium with the price. The higher the price becomes, the less inclined the customers are

to buy. And that makes the product all that much more difficult to sell. Quality and price are the factors that determine a good selling product. So the principle of quality control is to adopt a system of product quality which meets the customer's expectations, while at the same time, giving priority to market quality.

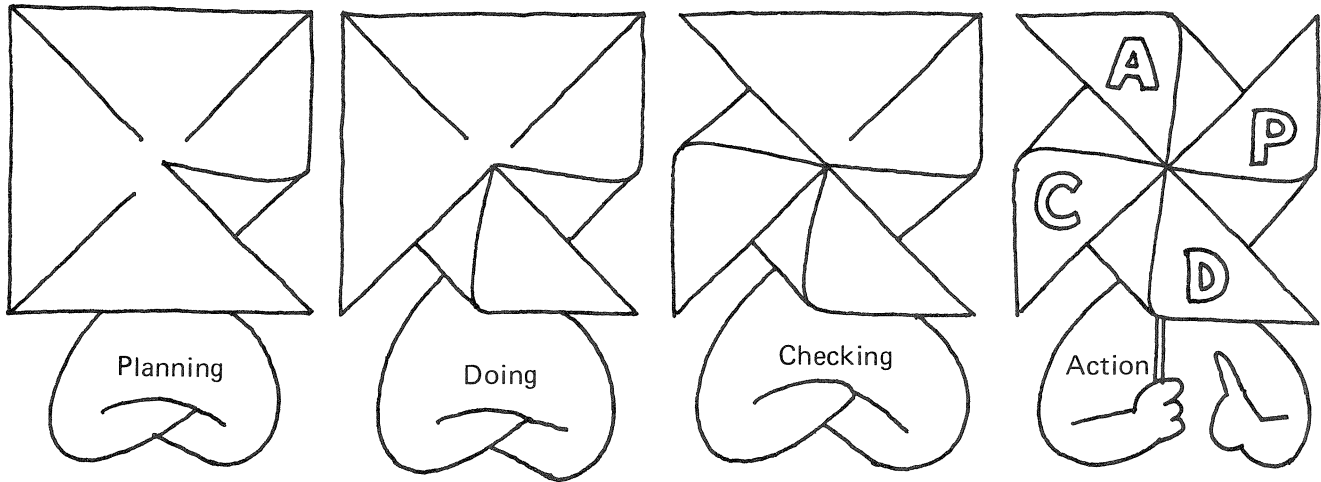

Standardization of organization

**What is the Point of Quality Control?**

Fundamentally, quality control can be broken down into the following aspects:

1. To determine the standards for a particular method . . . . . planning
2. To do exactly as determined . . . . . doing
3. To examine the results statistically . . . . . checking
4. To take action to correct any abnormalities . . . . . action

The very foundation of quality control is the continual repetition of Planning, Doing, Checking, and Action. Quality is what satisfies the customer's demand, and control is the continual repetition that achieves the quality goal.

In practice, each department covers a different aspect in one of the four areas. Their combined efforts result in the 'activities throughout the company.' And since quality control is based on statistics, that is, data showing the facts, misjudgements as a result of guesswork are eliminated. In quality control, there is no room for guesswork or sudden bright ideas. It can only be controlled by facts.

To think of quality control simply as a production process, or a series of examinations, is far from the

truth. First and foremost, quality control is knowing what the customers need, and the people who can best supply this information are those who are closest to the customers—the sales and service personnel. As for designing economical products to meet these needs, that is the job of the planning department. All the other departments, too, join in and render assistance, by making the tools that make the products, calculating unit costs and raising funds. All of which contribute to quality control—the very essence of corporate management.

In the inspection stage, products are pre-checked to make sure that they will operate satisfactorily when the customers receive them. But this is only a means of pre-judging the products to determine whether or not they meet the quality requirements, and to guarantee them. Although it is possible to guarantee quality solely be inspection, it becomes very uneconomical when none of the products pass inspection. It is far better to feed the information back and solve the problem at its source. After all, the whole point of quality control is not to reject inferior products, but 'not to make them.'

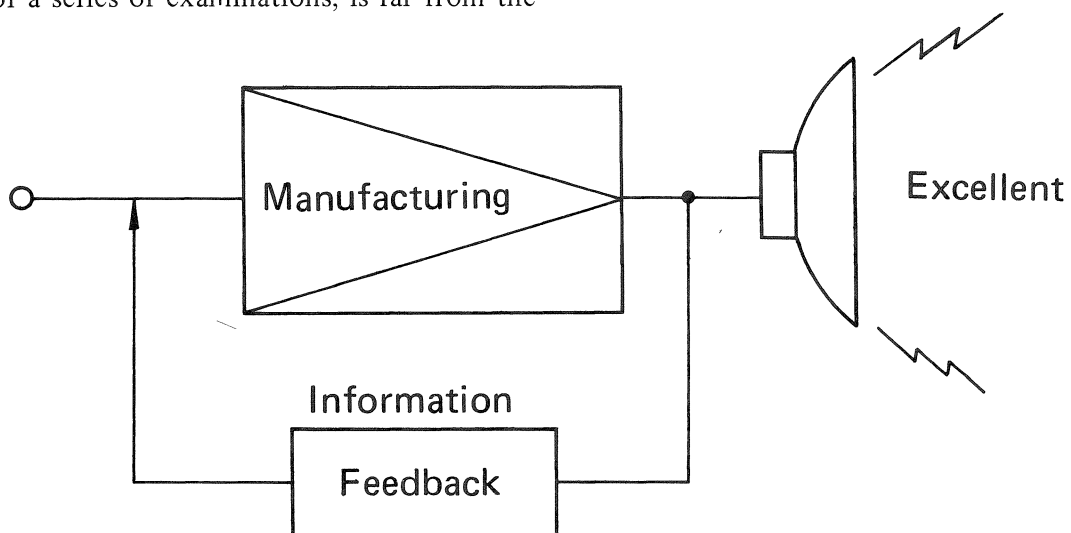

# Audio Memo

## White Noise and Pink Noise

White noise is an audible signal with constant energy per unit bandwidth. FM interstation hiss comes very close to being white noise. The energy of White noise increases 3dB per octave as the frequency becomes higher.

Pink noise on the other hand shares the constant energy/unit octave and does not increase in energy as the frequency increases. It follows, then, that

White noise filtered through a low-pass filter with a  $-3\text{dB}$  per octave characteristic comes out as Pink noise.

In ordinary testing, White noise is seldom left in "raw" form. Instead it is used after its spectrum distribution has been adjusted by various filters. The resulting Pink noise is helpful in the testing of speakers and networks.

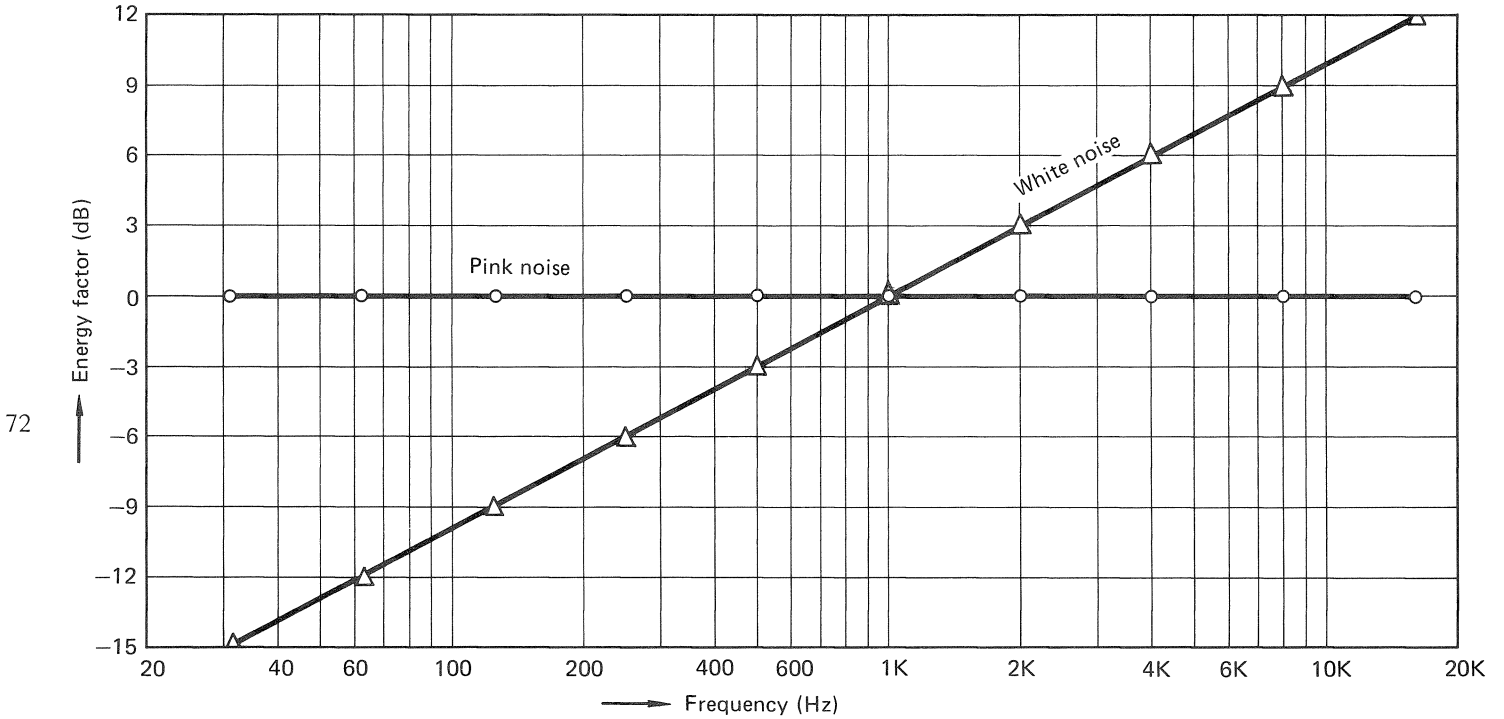

# Q & A

We recently received a question that we think would be of interest to many of you:

I purchased an amplifier whose rated power was 80W/ch. and also a speaker system whose maximum input power was 100W. However, when I played this combination at a party at high volume levels for a long period of time, I destroyed the voice coils of the midrange and tweeter. The wattage ratings of the equipment should have made this impossible. Can you explain how this might have happened?

Mr. T. McBright  
Philadelphia, Pa. U.S.A.

This is a question which arises frequently, and we think this might be a good place and time to address it.

- How can the voice coil of a speaker whose rated power is 100W be damaged by an amplifier whose rated power is only 80W?

To answer this question, let's start by looking at Fig. 1 which shows the relationship between the maximum input power of a speaker system and the input power from an amplifier. It is important to take note of the fact that there are two types of speaker power ratings: the 'rated input power' and 'maximum input power.' At the moment only 'maximum input power' is stated in catalogs.

The 'rated input power' is the input, measured in watts, which a speaker can safely accommodate on a continuous basis without any voice coil damage (see Fig. 1 (1), (2), (3), (5)). Even if the peak input power momentarily exceeds the speaker's 'rated input' the voice coils are safe. But it cannot be guaranteed when the larger input power is continuously supplied to the speaker for a long period of time. (Fig. 1, (4))

The maximum input power is generally determined to be twice as large as the 'rated power.' The rated output power of an amplifier, on the other hand, is a maximum continuous output figure that can be achieved without distortion when supplied with constant amplitude sine wave signals. Because the  $\pm B$  voltage of the power supply never decreases when fluctuating signals are applied, a power output greater than the rated power can be achieved. If we disregard distortion, we can easily obtain this larger power output figure from an amplifier (theoretically twice the rated continuous power).

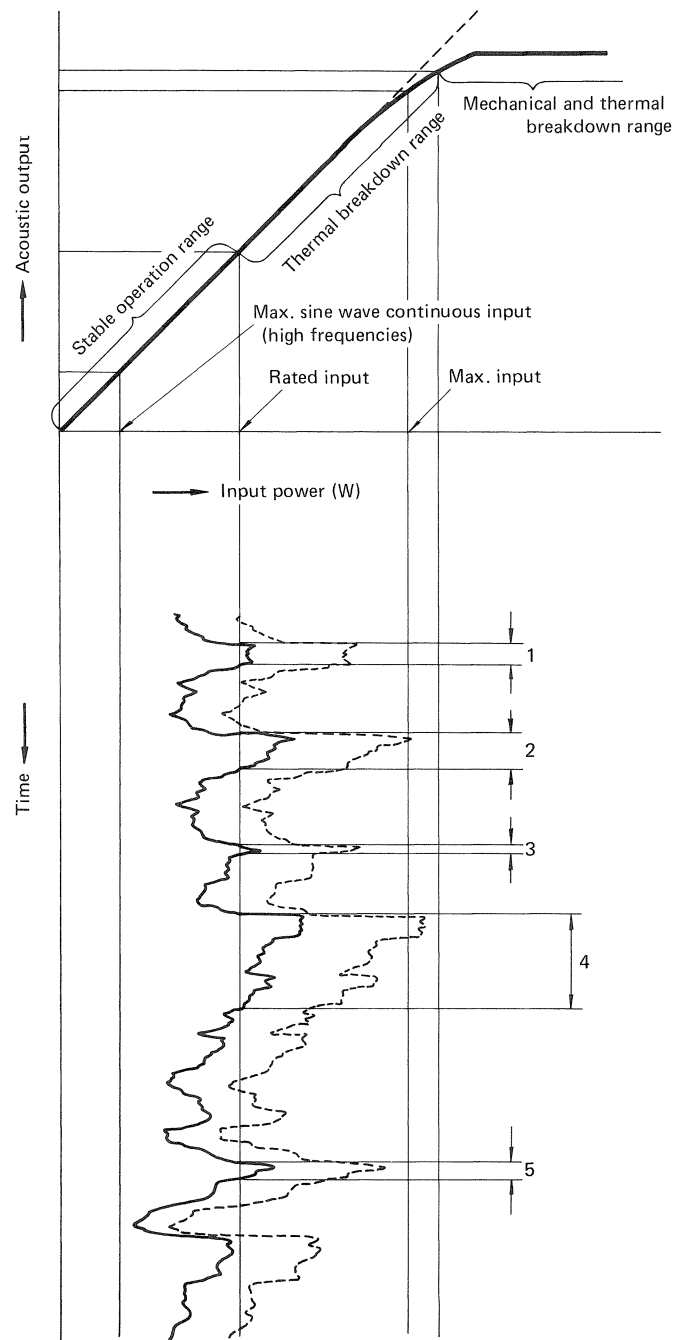

Fig. 1 Withstanding input power characteristic vs. input power of a speaker system

So what happens to the speaker under the conditions in Mr. McBright's question? The solid line in Fig. 1 shows an input close to the allowable maximum input power of the speaker. When the volume is turned up, the output power looks like the broken line in Fig. 1. (In this example the output of the amplifier exceeds the 'rated power' of the speaker by 1.5x) It's obvious that the average power input exceeds the 'rated power' input. The degree of excess depends on the program source. Rock music, especially when played at parties is often very loud with distortion not being a primary concern. In such a case,

the peak power of the amplifier exceeds the maximum input power of the speaker. It was this situation which burned out the voice coils of Mr. McBright's speakers.

The midrange and tweeter are the elements that are adversely affected. The reason for this is that when the output power becomes excessively high, the resulting distortion of the harmonic components is fed rather to the midrange and tweeter than to the woofer. For your information, the test conditions are shown in Fig. 2.

'Rated Power': There should be no abnormality after applying pink noise for 96 hrs. Power input is derived with the following equation.

$$P = \frac{V}{R}$$

The voltage value is taken with a thermoelectric voltmeter.

(V: rms)

Max. Power: There should be no abnormality after applying a vocal or musical signal for 96 hrs. The source of the test signal should be FM or AM broadcast whose level is regulated.

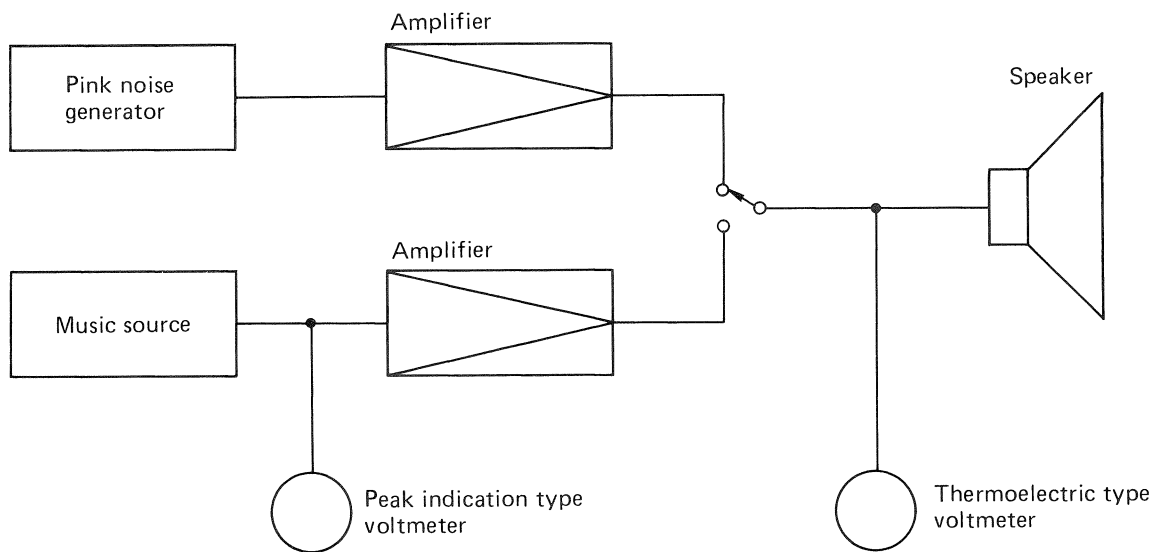

Fig. 2 Withstanding input power testing of the speaker



# IN THE NEXT ISSUE

1. New Products .....CT-F1000
2. Parts Information (2) .....Coils and Transformers
3. Electricity: Basic Theories (3).....Electric Power and Sine Wave
4. Measuring Instruments (3).....mV Meter
5. One-point Servicing Techniques (3)..... IF and MPX Adjustment
6. First Step in Audio (2) ..... Specifications—2 (RF)
7. Quality Information System (2)
8. Q & A

Publisher  
Ikki Nagashima

Service Section  
Administration Dept.  
International Division

---

## Editor's Note

---

75

- Our maiden issue of Tuning Fork was received with great enthusiasm, and we heartily appreciate the words of encouragement that we have been receiving from readers all over the world.
- In this, the second issue, we have changed our editorial orientation somewhat. We have tried, as much as possible, to address every article to the day-to-day practical servicing problems you encounter in your work. If you have any specific questions about any of the articles, please let us know.
- We realize that we promised you a November issue of TuningFork. Planning-Doing-Checking is as important to the publishing business as it is to any field requiring QC.
- Between the first and second issue, we put out the supplement "Countermeasures for Automotive Static". We hope you found it helpful for car stereo and car radio servicing applications.
- Tokyo's annual All Japan Audio Fair took place at the end of September, and once again attendance was heavy, amounting to more than 220,000 audio fans. Manufacturers outdid themselves with attractive display pavilions and demonstrations of all their new equipment. And, of

course, Pioneer outdid them all with the introduction of a number of exciting new products; quartz synthesizer tuners, magnified power range amplifiers, tape decks, and turntables. Speakers in the Pioneer line continue to benefit from the incorporation of new materials, and the improved sound was noted and appreciated by visitors at the Pioneer pavilion. These new products have just been introduced to the Japanese market and will reach your area shortly.

- New products with new technology require competent up-to-date service people. Progress in the audio field seems to accelerate every year, so it is essential that we improve our skills at the same pace. To this end, Tuning Fork was instituted for your benefit. We hope that it serves you well.

T. Taguchi  
H. Koike  
A. Kogirima



**PIONEER ELECTRONIC CORPORATION**

4-1, Meguro 1-Chome, Meguro-ku, Tokyo 153, Japan

**U.S. PIONEER ELECTRONICS CORPORATION**

85 Oxford Drive, Moonachie, New Jersey 07074, U.S.A.

**PIONEER ELECTRONIC (EUROPE) N.V.**

Luithagen-Haven 9, 2030 Antwerp, Belgium

**PIONEER ELECTRONICS AUSTRALIA PTY LTD.**

178-184 Boundary Road, Braeside, Victoria 3195, Australia

**PIONEER ELECTRONICS OF AMERICA**

1925E, Dominguez St., Long Beach, California 90810, U.S.A.

Printed in Japan